

Engineering Graphics and Design
Professor Naresh V Datla
Department of Mechanical Engineering
Indian Institute of Technology, Delhi
Lecture 25
Week 5: Auxiliary and Section views
Example: Section View

Good morning everyone. So, we are back for week 5, where we will be doing the drawing for auxiliary and section views. Already the lecture has been covered in the class by Professor Datla. So, today, we will be doing the practical for this.

(Refer Slide Time: 00:39)

Q1. Figure below shown an object. Assume that it is cut symmetrically by a cutting plane. Arrow in the figure shows the front viewing direction. Draw its top view and sectional front view.

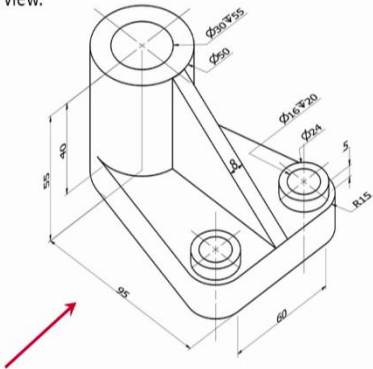

The isometric view shows a mechanical part with the following dimensions and features:

- Overall length: 95
- Overall width: 60
- Overall height: 40
- Top cylindrical part: diameter $\phi 30$, height 15
- Intermediate cylindrical part: diameter $\phi 20$, height 5
- Bottom cylindrical part: diameter $\phi 16$, height 5
- Right cylindrical part: diameter $\phi 16$, height 5
- Right cylindrical part: diameter $\phi 20$, height 5
- Right cylindrical part: diameter $\phi 24$, height 5
- Right cylindrical part: diameter $\phi 15$, height 5
- Red arrow indicates the front viewing direction from the left.

TV

 FV

NPTEL
2

Engineering Graphics and Design

Top Viewing Direction

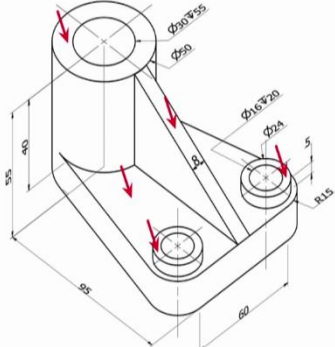

The isometric view shows the same mechanical part as in slide 2, but with red arrows indicating the top viewing direction from above. The dimensions and features are the same as in slide 2.

NPTEL
3

Engineering Graphics and Design

So, here is our problem, problem number 1. If you look at the problem, you will see, that there is a simple object and we have been asked to draw its top view and sectional front view. So, today, we will be demonstrating you using the object itself. Like just from the drawing, it is not always possible to visualize the object that is why we decided to bring an object in the class. So, if we look for this object, the front view direction is this. And we have to ask to draw the top view as well as sectional front view.

Now, you just look at this object, and then look at this. This is the object what you were watching in the drawing. The same object, but today, we will not rely only on the drawing, but we will look at the object also. So, first, we will look at the object in the drawing, then we will come back to the real object, then we will go for the drawing. That is what we will do.

So, our first question is the top view. If we want to draw the top view, what we will draw the top view on top of the reference plane. Neither third nor first angle projection is mentioned here. However, if nothing is mentioned, we will go with the third angle projection. And in the third angle projection, the top view will always come on top and front view will come below the top view.

If this is the top viewing direction, what are the objects we will be looking at? The first object we will be looking at is this this circular part, this rib, the small circular part and this open area. These are the parts we will be looking at from the top and we have to draw the projection on these parts.

Now, let us come back to the real object. If you look at the real object, this is the, if you look from the top, this is the first part. This is the first part you have to take. You have to take this part, you have to take this rib, you have to take these things, if you look from the top, and you have to take this part also. So, these are the things you should be looking at from the top. Now, we can go for the drawing.

(Refer Slide Time: 03:37)

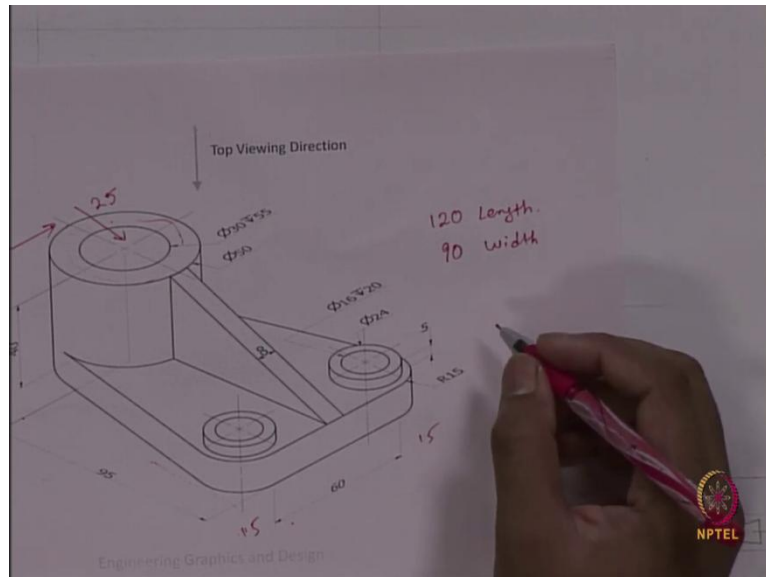
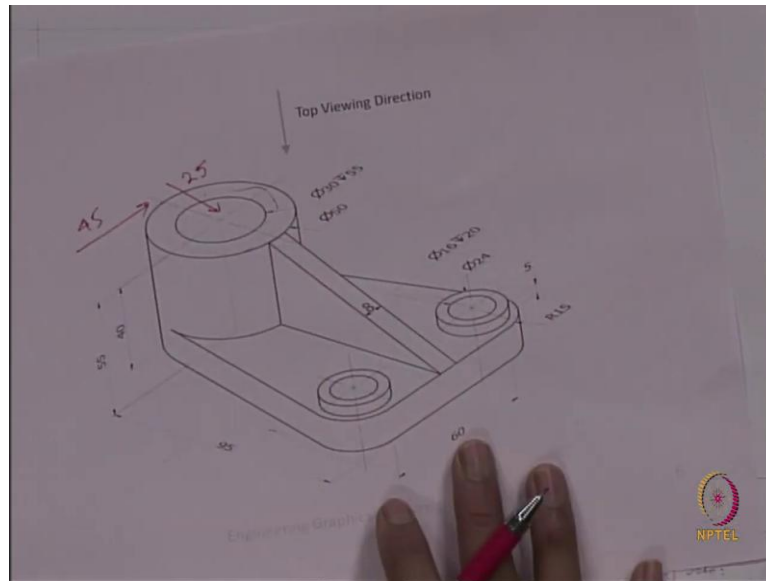

Here is our drawing sheet. The drawing sheet already has been prepared. In the previous labs also we have shown how to prepare the drawing sheet. So, the name, unit is in millimeter, scale is 1:1, and third angle projection shine. These are the things we will be getting here.

Now, if we go to the drawing. This is the top viewing direction. The first thing we will be looking at is this circular part. We will start drawing with this part. What is the diameter of this part? The outer circle has a diameter of 50, the inner circle has a diameter of 30, and the center is situated at a distance of 25 from left side and 45 from this side. From this side, it is at a distance of 45, the center, and from this side it is at a distance of 25.

Before drawing the top view, I have already decided what will be my drawing area just from the dimension. If you look at the dimension 95 plus 25. So, for in the case of top view 120

will be the length and if you look at that width 60 plus 15 plus 15, 90 is the width for that top view.

So, that much area actually I have covered before starting the drawing itself, so that, my top view will be within that area. So, you should also have an idea like where your top view and front view will be. So, based on this I have already mentioned in previous classes also. Based on these you should draw the reference line, you should take the gap from reference line and you should identify the zone where you will be drawing.

(Refer Slide Time: 05:56)

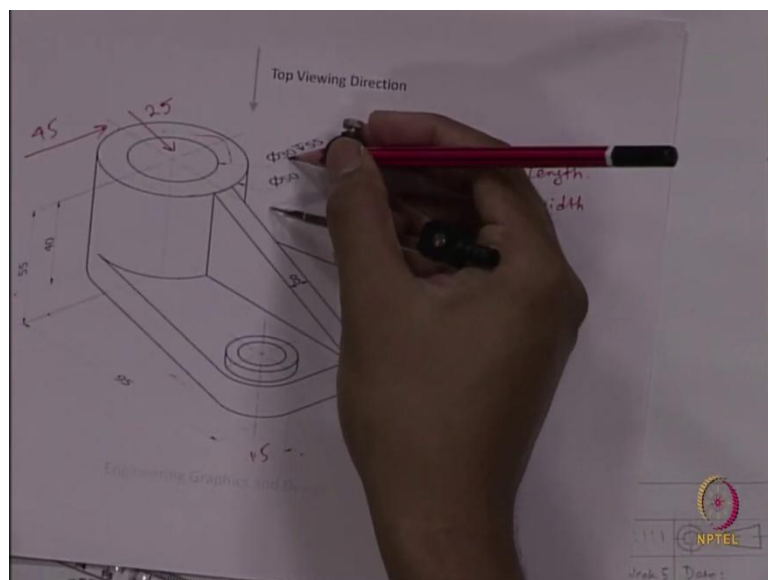
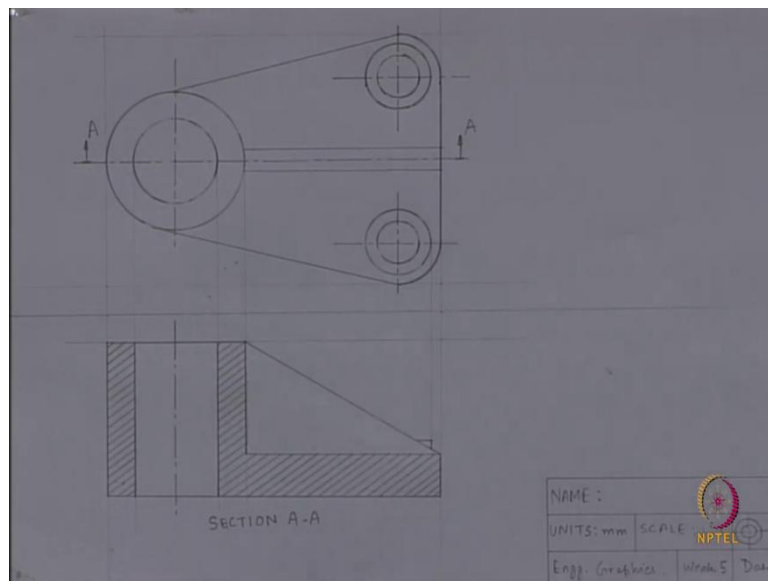

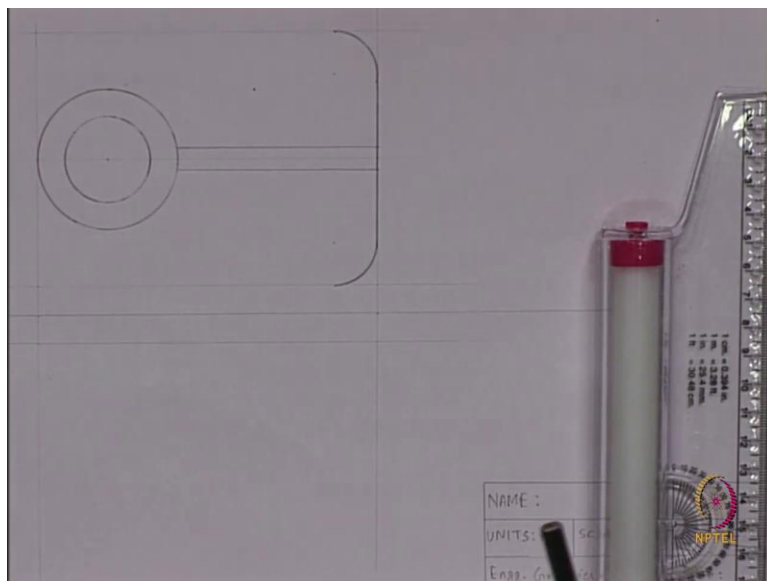
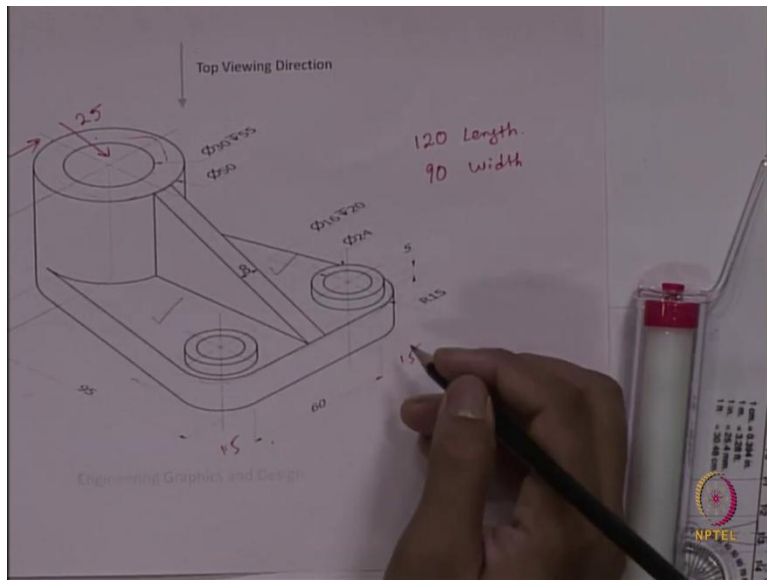
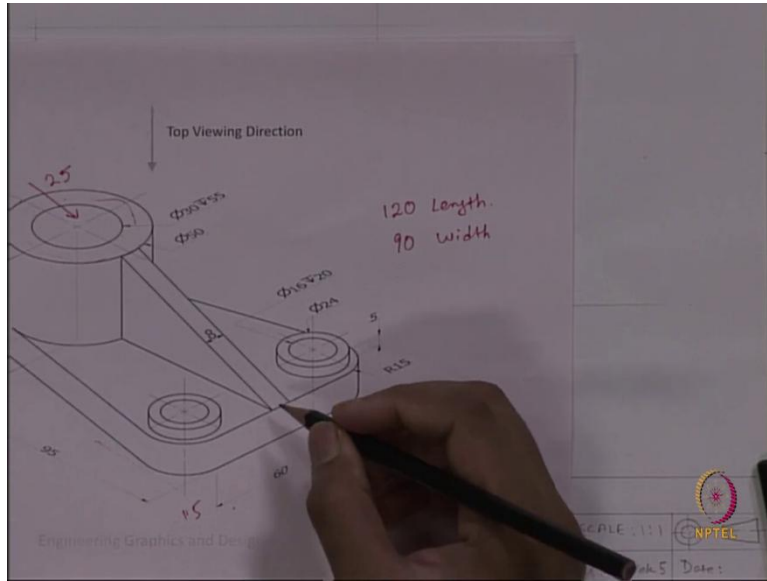

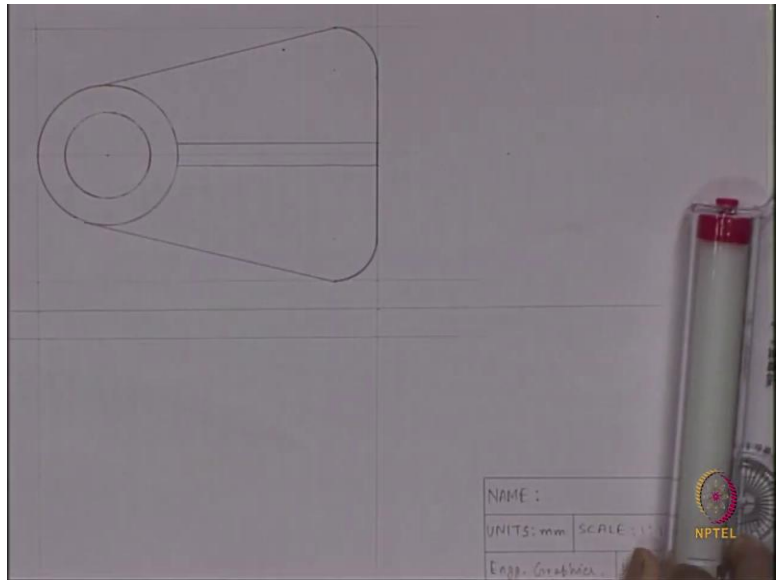
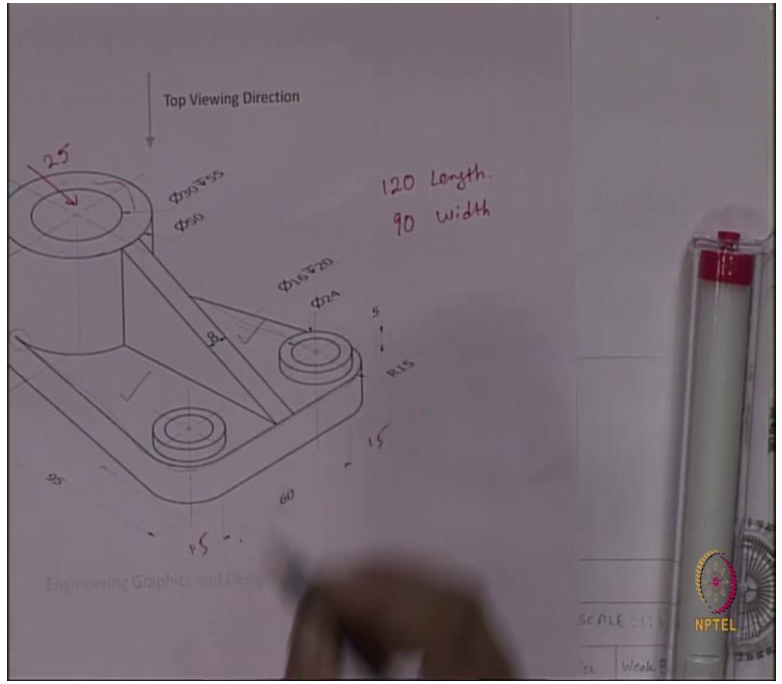

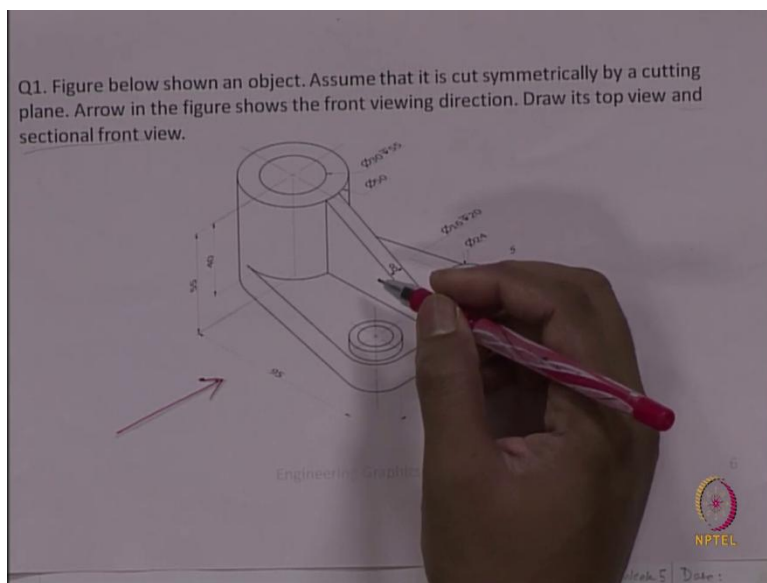
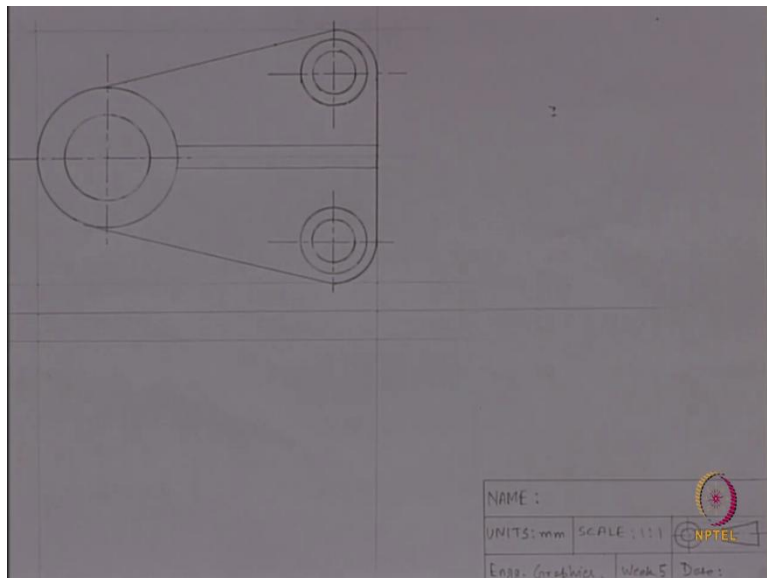
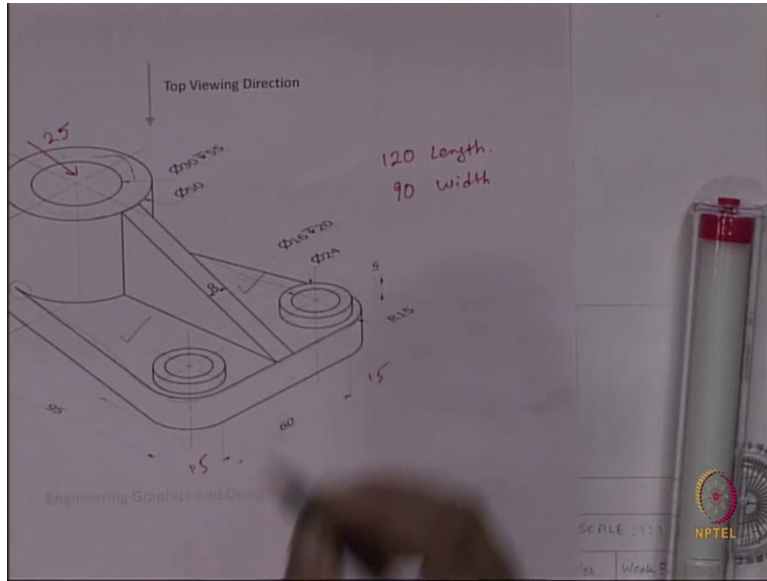

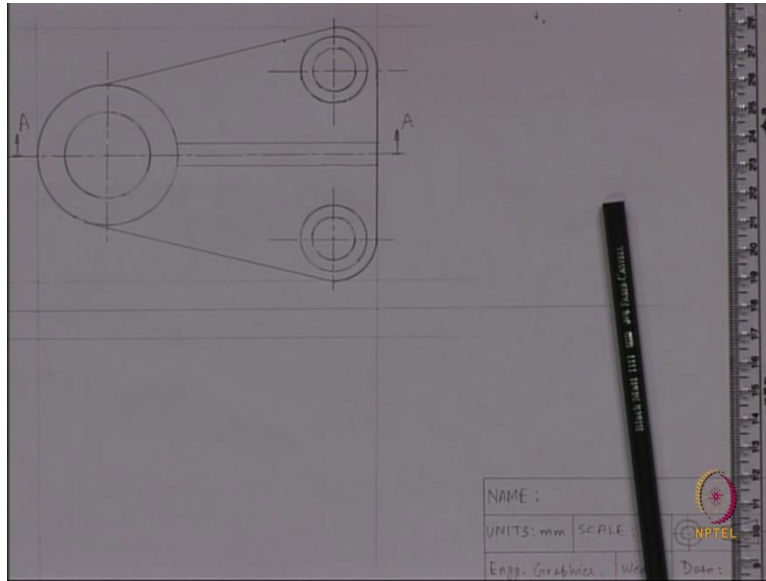

So, for top view the first thing we will be going is the circle the center is at a distance of 25 and at a distance of 45 from this line. The center is this. And if we draw the outer circle has a dia. of 50, inner circle has a dia. of 30. We have to check the diamond from here. Bigger circle, we have drawn the smaller circle has a dia. of 30, that means, a radius of 15 we have to choose. We have drawn both the circles.

Now, the next part is this rib, we will draw this rib, and this rib has been started from the end of the circle and this ended here. If we look the rib in this zone, you are looking first at this circular part, then the rib is coming. The rib has been started from here and ended here. If you look at from the top, you would not see an inclined surface rather, you will see just two lines a simple rectangle you will see instead of a slanted rectangle. That we will draw.

It has a width of eight, and the length is 120 minus 50. That is 70. As it has a width of 8 and it is symmetric the length is automatically, we will get a length of 70, and the edge will simply close it. The next part we will see is, this area, this plane, these two plane area. So, what we will be looking at? If we look from the top, we look at this sideline. We will look at the whole sideline and these corners have a radius of 15.

If you look to the body, the whole surface we have to draw. We will just see the outline while looking from the top and this corner, this is, there is an arc, this top arc, this has a radius of 15 that we have to draw first. We have to mark the center point for this 15 here, 15 at the top. Similarly, on the other side also, and we will draw an arc of 15. After joining this arc, we will join this line, so that we will get that a boundary for this.

We have got this line, now, we will draw this and this line. This line and this other line those are tangent to this circular part. So, if we look from the top, it will be simply a tangent to the circle. And on the other side it will be a tangent to the arc. Here it is a tangent, here also it is a tangent. What is the part left here? These two circular holes. And it has a boundary like there is an outer dia. of 24 and the inner dia. of 16, and this is in the both side, and this is concentric with this arc. So, we will use the same center but we will draw a circle of 24 then 16 in this side and in that side too.

First dia. is of 24, so the radius will be 12. Similarly, here also a circle with radius 12 or dia. 24 we have to draw. We have drawn the bigger circle. The smaller circle again, you have to draw, but the smaller circle has a dia. of 16 or a radius of 8. One circle is done, the another one we have to draw again.

So, we are mostly done with the figure. But only you have left with some parts in the top view that is, as these are circular parts, we have to show the center line. The center line we have to show for all the circles. And when I will show the center line I will be showing it using bigger dash and small dash.

And when you will be doing this line or you will be drawing this line you should always remember that you should draw it at a ratio of 6:1. The bigger dash has a length of 6, the smaller one has a length of 1 like this, in this side also 6,1; 6,1; 6,1; 6,1. For these two circle also similarly we have to do, 6,1;6,1;6. So, the top view is completed, but still, we have to look at something.

If we see that question that it has been asked draws its top view and sectional front view. So, if we want to draw the sectional front view, what is the front view here? The front viewing direction is this, and front view means, we will look from this side. So, in the top view only, we have to choose the cut plane, then only, we will be able to see the sectional front view. And where we will choose the cut plane, that we will understand with the body itself, with the object.

This is the object, this was the top view, and if you look from the front that will be the front view. And if I section it through this plane. Where should we section? The section rule is actually after sectioning you should be able to see or you should be able to understand the most of the features. What are the internal features in most cases?

So, this time we have chosen this cutting plane so, that we know what is the internal feature of this area. And after cutting what we will be looking at that I will just show you, but first I will draw the cutting plane. The cutting plane is this vertical plane, that I have to show in that top view, I have to represent that.

This whole line, this is representing the cutting plane. Here I will show one arrow, that this will be the viewing direction after cutting. In this side also similarly. The name of the cutting plane let's say A-A. And we will bold this part, so this is the A-A cutting plane. And if we cut along this plane and this arrowhead is pointing at the viewing direction, both of the arrowhead are in this direction means we are looking from here, we are viewing the other part. And what the object will look after cutting, that I will show you now.

(Refer Slide Time: 19:19)



We have already shown you the cutting plane and after cutting this is what you will be looking at. See, now, you are able to look at the inner features. Previously, you were not able to, but now you can look, this is the sectional front view. This you have to draw exactly, what you are looking at from the front that only we will be drawing now.

So just look at the features this part, this part, this part. This part have been sectioned, so we will be using sectioning lines also for those parts. This is the rib. This has also been sectioned but we will not be using any sectioning lines that I will explain you later. But just look at this how it looks like and we will draw it. You will look at this, this this part, this rib and a small protrusion of this part. These are the features we have to draw.

(Refer Slide Time: 20:32)

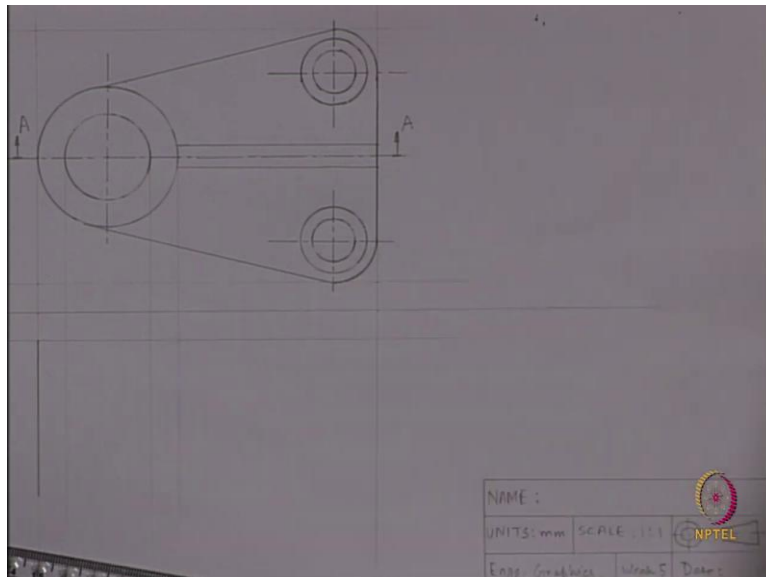
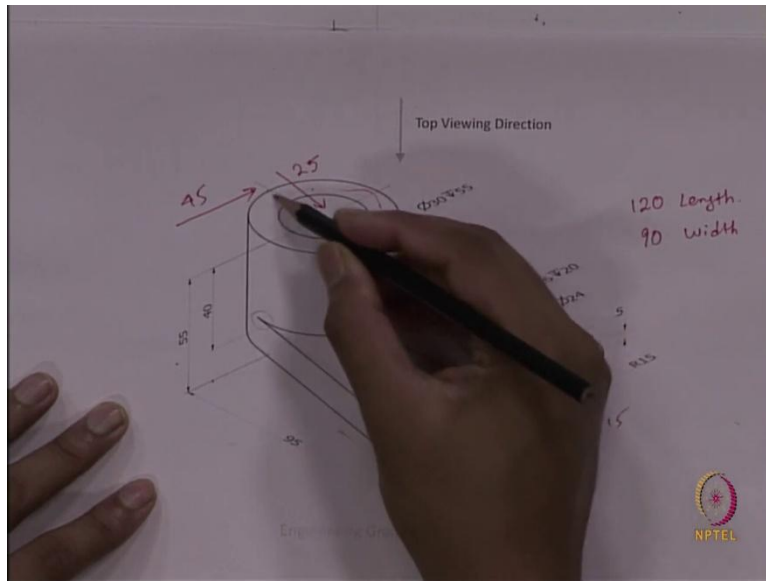

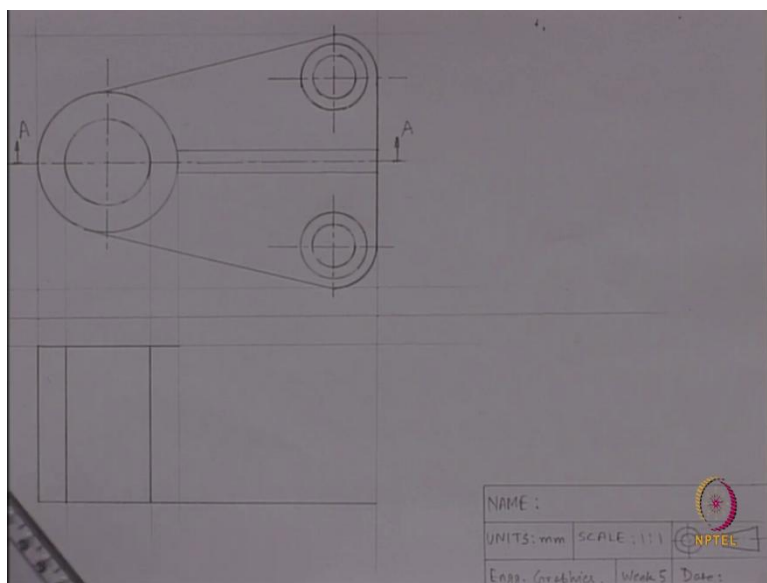
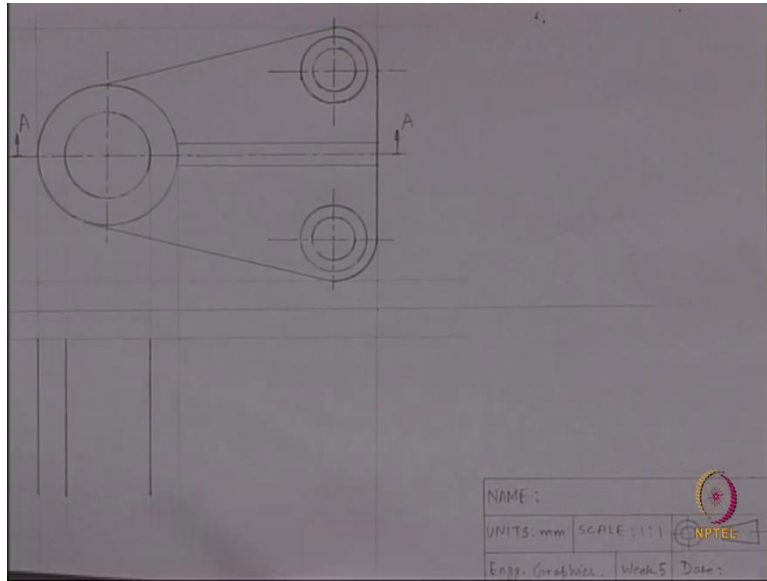

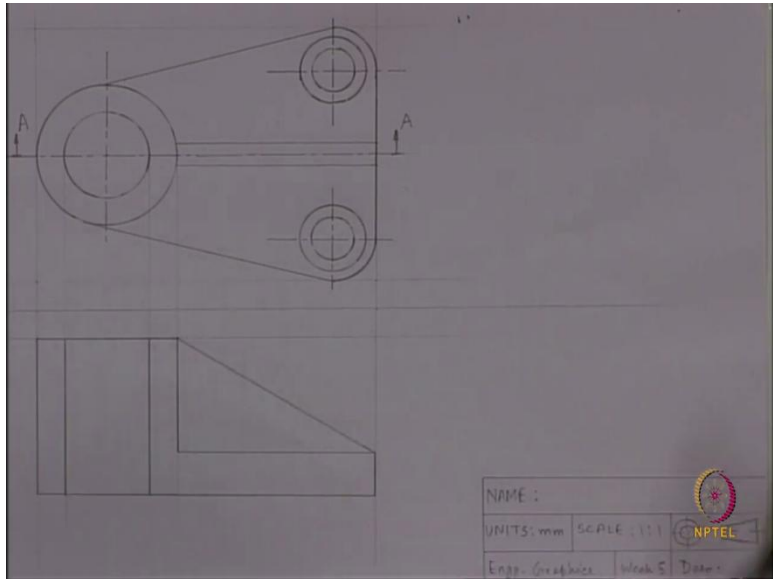

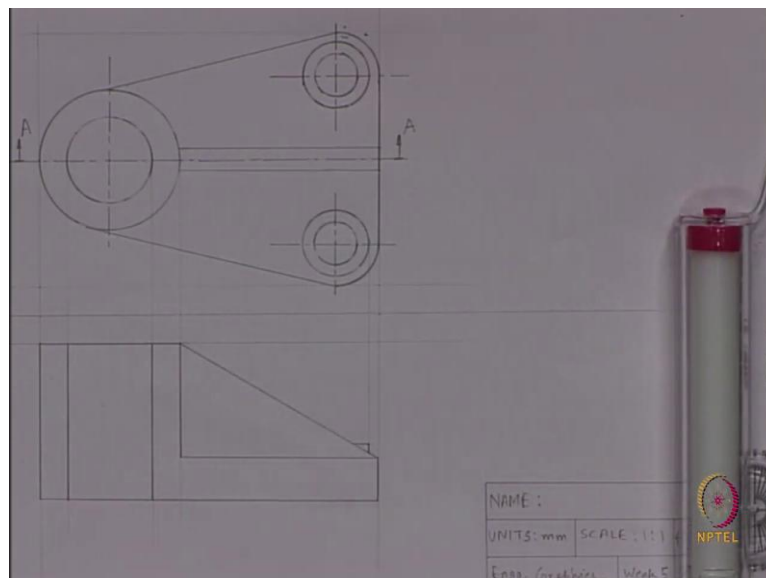
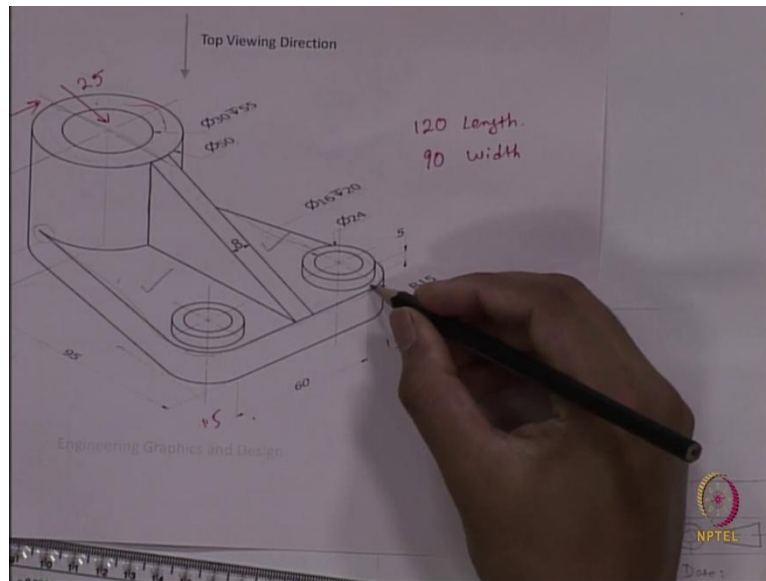

The first part we will be drawing the sideline after sectioning, it has a length of if we look at the length, the length is 55, and this width is 50. You can either directly measure it from here 50 or you can just take a reference from the top view, because our top view is already drawn. So, we can just use those references, like, where those parts will be, we can just understand just from the. So, these are the sidelines of the sectioned part that we have to just we have to, this like will draw this line we will draw this line also we will draw.

This line will also have a length of 55. Similarly, this also and the whole lower part, this line, this curved line and this whole line, if we look from the front, we will look a single line instead of all this, and that has a length of 120. Top line also I have to join. We would not see any curved line here, instead, we will see only a single line. This line was actually carved in the 3D figure, but we will look as a single line only.

Now, if you look this line, we have drawn, but there is a line between the rib and the main part that, this line also we have to draw. Because rib is a supporting part. Rib, nut, screw, bolt like these are the supporting parts, we cannot show it as the parts. Like, we have to keep a distinction between these two. This and this part we have to draw a line in between and we have to differentiate this using those lines.

So, the rib has a height of 40 and a length of 70 that we have to draw here. Height of 40 and a length of 70. I will join the end because, and this is the outline of the rib that you can see in the sectional front view. This outline, this whole triangular rib we just drawn. So, these are the all parts or anything left?

In sectional front, we will not only draw the sectioned parts, but whatever else is not sectioned, but still you are able to see you have to draw that. In that case, if you look from the front you will see a small protrusion of this part, that also you have to draw otherwise our drawing will not be completed.

So, if we look at this part, this has a height of 5, and this is situated at a distance of 3 from this, 3 from this end line. At a distance of 3, and at a distance of, at the height of 5. And again, you can take the reference from this component also. If I join this, yes, that is the protrusion. I could look at in the sectional front view. Now, the most important part, which I have not drawn is the section, which part have been which of the parts have been sectioned here that we have to understand first.

(Refer Slide Time: 26:58)



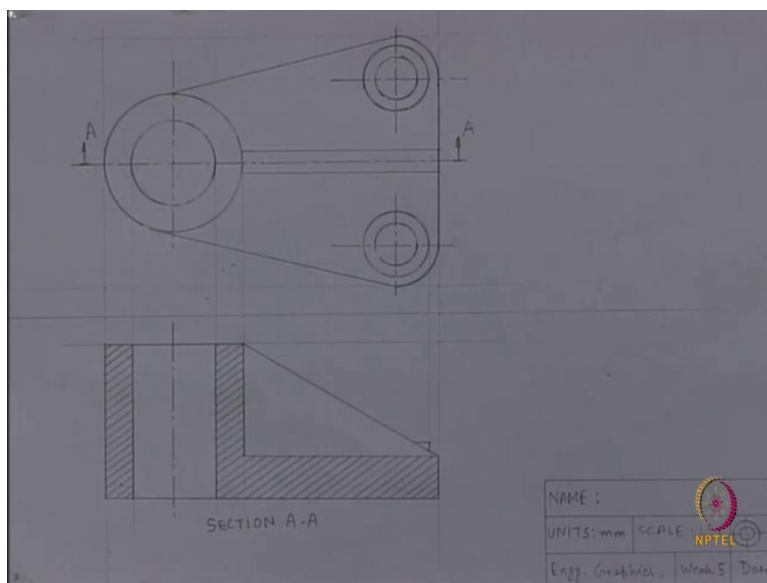
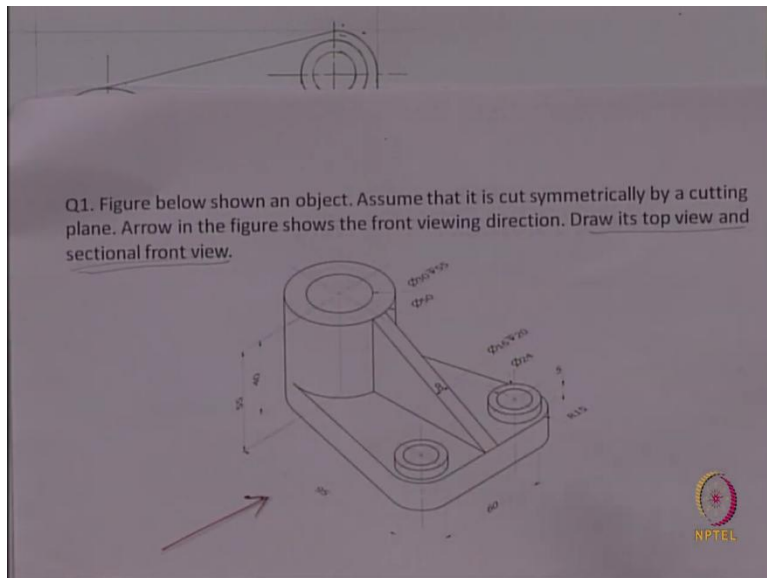
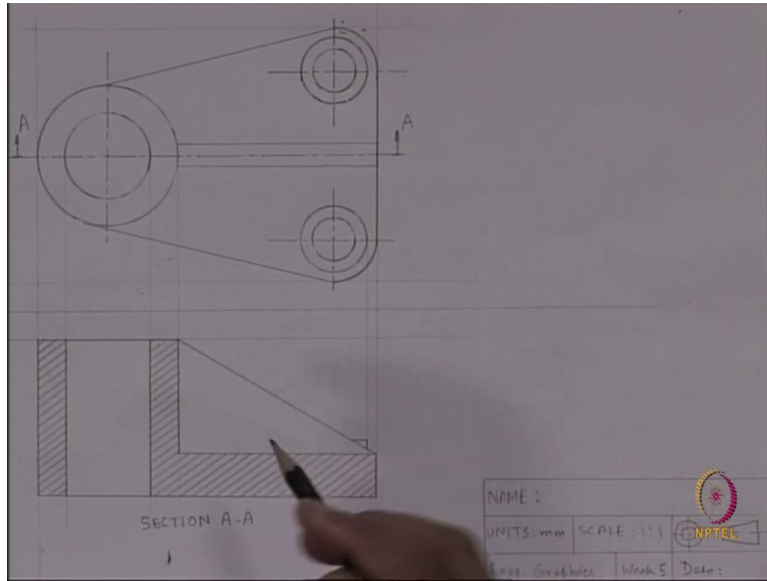

Look at this. These parts have been sectioned, this part have been sectioned, and the lower part. We will not consider the rib here because the rib is very thin. This has only been used to support this. If we would have been sectioned in this direction, then behind the section line there would have been a lot of material in the ribs. So, we had to show the sectioning in rib also. But in this cutting plane, after the cutting when there are like there is a very few amount of material in the rib, so we would not show that using sectioned lines.

You can see now, I have just drawn using some sketch pen the sectioning lines, the part which I have been sectioned, this, this and this. So, these are the part, which was cut during the sectioning. We have to draw the same thing in the sheet also. So, you have already been asked in the class how to draw the lines. So, for that first I have to choose the 45° angle. Because we used to use 45° angle for this. I am using 2H pencils for the drawing again I am reminding you. And in between two lines there will be a gap of 2 millimeter. So please keep those things in your mind when you will be drawing the sectioning lines.

After we draw the sectioned lines for the whole part. See our sectioning is complete. While you will be doing the sectioning you have to maintain some of the things, like angle of 45° mostly, but when there will be multiple sections you can use different angle also like 30° , 60° , 135° those kind of angle you can use. And in between two sectioning lines, there should be an even gap of 2 millimeter here we have taken, you can take a 3 millimeter also, if it is a bigger section. And the section should not go out of the boundary line.

That also you should always keep in mind. And this was the section view for section A-A. We have cut along this section and this was the viewing direction and after that, we will be looking at this. If we look at the question paper. just we have been asked to draw its top view and sectional front view. And dimensioning, we are not asked to do the dimensioning, so we won't do it.

So, this is our top view and sectional front view. This is our cutting plane. So, actually we have forgotten to draw this part, but we need to draw this center line also. Center line corresponding to that whole 6,1;6,1;6,1;6,1. So, with this, actually, we are done with our question number 1 of week 5. So, after this, we will go to the example number 2, where we will deal with auxiliary view. Thank you.