

Energy Conservation and Waste Heat Recovery
Prof. Prasanta Kumar Das
Department of Mechanical Engineering
Indian Institute of Technology, Kharagpur

Lecture – 22
Gas Turbine cycle

Welcome back; so in last few lectures we have covered I have covered steam power plant and steam power cycle and with different examples we have seen the variations in the basic steam power cycle. Now steam power plant is one of the prime methods of converting the energy of fuel into useful work, that is, ultimately into electricity and the modern civilization is dependent to a very great extent on the energy that we get from steam power plant. Large amount of energy demand is supplied by steam power plant.

Another power cycle which is also very important, that is the gas turbine power cycle. Now, gas turbine power cycle or gas turbine cycle is not only used for generating power in a ground base plant, but it is also used in transportation particularly for aviation, but what is our concern that is gas turbine power plant which is used for generation of generation of power and not as the power plant of a of an aircraft though the working principles are quite similar.

So, gas turbine as steam power plant is basically based on coal, but there could be other fuel even there could be nuclear source of thermal energy. Gas turbine also can use different kind of fuels for aviation purpose of force liquid fuels are used, but for power generation land based gas turbine power plant they can have different kind of fuel they can have different kind of fuels. In the solid fuel by burning solid fuel one can one can get hot gas and that hot gas can be used for gas turbine even gas coal nuclear reactor that can supply thermal energy to gas turbine power plant. Coal gasification is another possibility by which one can have gas turbine power plant.

So, there are number of possibilities of fuel and gas turbine power plant are generally less bulkier, compared to a steam power plant. So, there are other advantages of gas turbine power plant though it has got also certain limitations. Now what I like to do is that?

(Refer Slide Time: 03:33)

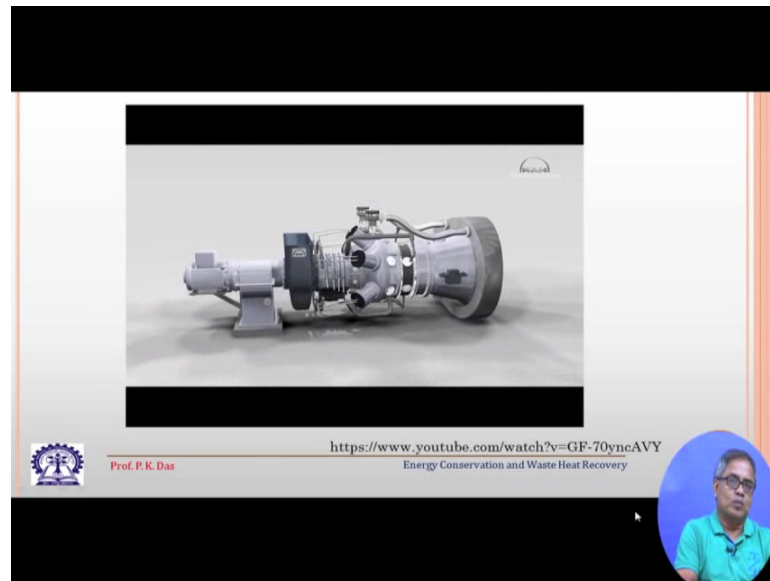

From YouTube you can see; inside the highly efficient mg t 60100 and mg t 60 set a milestone in the 6 mega watt output glass let us look at the mg t 60100 first it is a twin shaft model used as a mechanical drive for compressors for example, the compact core engine delivers a maximum output of 6.9 megawatts. This is equivalent to 9522 horsepower plus as much as 95 anima beal engines of 100 horsepower each produced together. The mg t 62100 basically comprises two sections. The gas generator with high pressure turbine on the left and the power or low pressure turbine on the right which runs independently of the gas generator at a variable speed thanks to a second shaft.

An external drive starts the gas turbine. In this case it is an electric motor which drives the shaft of the high pressure turbine and along with this the 11 stage axial compressor mounted on it.

(Refer Slide Time: 04:49)

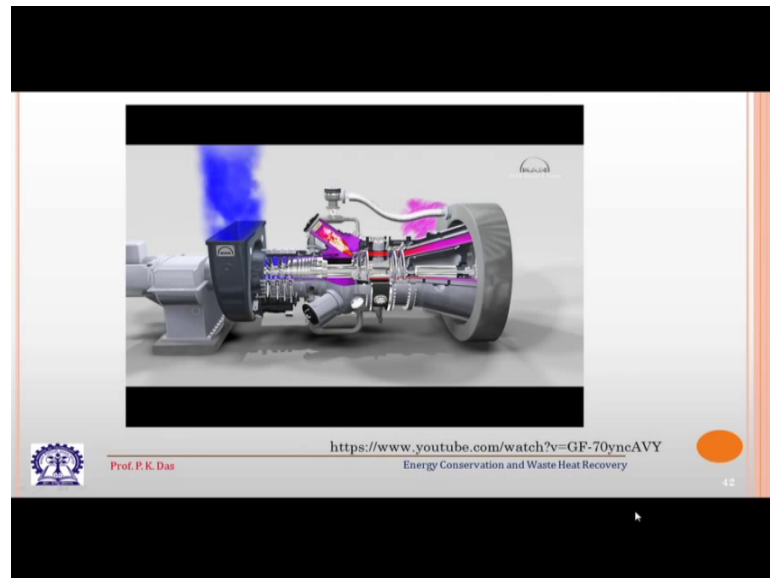

The compressor driven by the high pressure turbine serves to take in and compress the air needed for combustion. Inside the 6 combustion chambers the air is mixed with fuel gas and the mixture is ignited. The hot exhaust gasses expand driving both the high and the low pressure turbines.

Let us take a closer look at this process due to the spinning motion the blades of the axial compressor strike the air, they conducted into the turbine while compressing it in the process a flow is created that passes through the air intake casing and then along the axis a pressure increase of 15 bar means the air flows into the 6 combustion chambers with around 15 times more oxygen. These advance can combustors premix the fuel gas with the compressed air homogeneously, already before it enters the chamber.

Afterwards, this mixture is ignited and burns with extremely low emissions. The fuel gas air mixture expands due to the combustion heat to many times its volume, as a result it flows at high speed first through the two rows of blades of the high pressure turbine and then through the low pressure or powered turbine thus driving both shafts.

The exhaust gases flow through a diffuser into the outlet casing their high temperature of around 460 degrees Celsius can still be utilized. For instance, to generate steam the shaft of the power turbine can be operated independently of that of the gas generator in a speed range of 45 to 105 percent of the nominal speed of 12600 rpm and thus adapt optimally to the requirements of the machine to be driven.

(Refer Slide Time: 06:29)

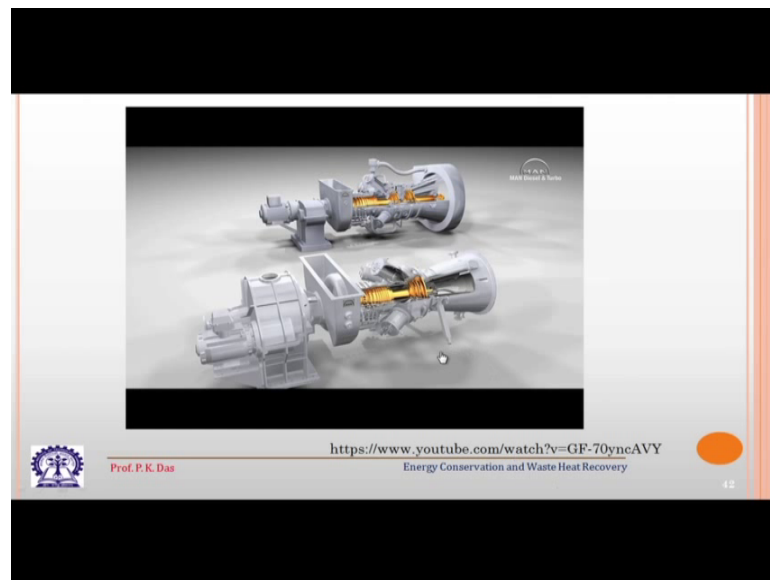

However, such a flexible speed range is not necessary to generate power, that is why man has come up with the mgt 60100 this single shaft model drives an electric generator.

(Refer Slide Time: 06:41)

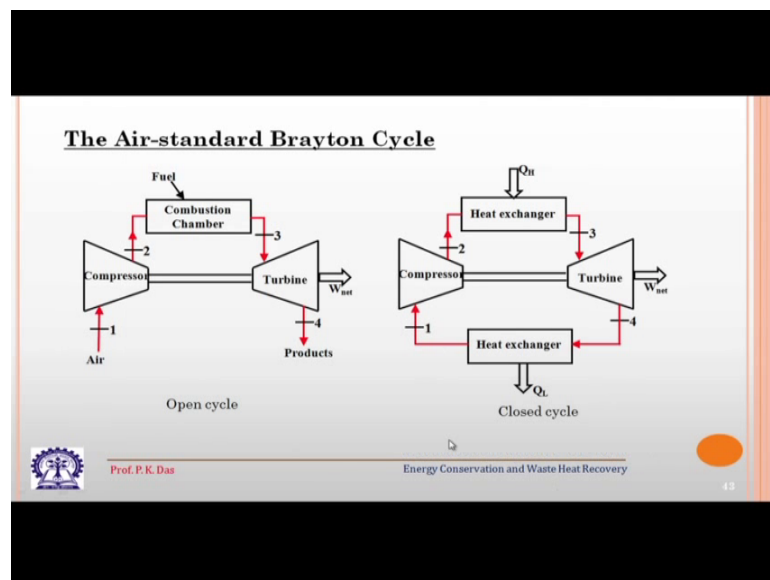

So, I have started with some sort of animation for gas turbine power plant which is taken from YouTube reference has been given and some relevant portion of it has been shown to you. And, then I think we will be able to appreciate what the cycle diagram and the different components etcetera.

So, basically in a gas turbine power plant air is taken from the ambient atmosphere and it goes to a compressor. So, air is getting compressed, then after that the compressed air is sent to some sort of a combustion chamber and fuel is injected in this. So, fuel could be a liquid fuel. Combustion takes place the gas was having a high pressure now it is having also a high temperature and then it goes to the turbine. So high pressure and high temperature gas that expands through the turbine and then the turbine produces work not only the turbine produces the work for running the compressor.

But it will also produce excess work w_{net} which can be utilized for some purpose. Electricity can also be generated or it can be used for directly driving something see in the animation they told that turbine could be used for running it another compressor or some such system, but for electricity generation it can be used. And then the hot product of combustion which expanded through the turbine given some amount of energy to the turbine, but it will still have some high temperature that will come out of the turbine.

So, this is a potential source for recovering energy for recovering wasted. This has been mentioned also in the animation you have seen. So, this is the actual cycle which is there in a gas turbine and the product of combustion that goes to the ambient atmosphere. So, the cycle is an open cycle, because the working fluid as working fluid air is taken and it will change its chemical composition after the combustion. So, it cannot be made into a closed cycle as long as the combustion process is there for imparting energy to the working fluid to the steam of working fluid, but for idealization; what we assume that it is a closed cycle this kind of cycle is called air standard cycle.

So, for air standard cycle what we will assume that the compressor is taking air and that is getting compressed. And then it is passing through the air is passing through and heat exchanger where combustion is not taking place, but it is being added from some sort of a suitable source. Then that hot high pressure gas goes to a turbine and it expands the turbine runs the compressor plus supplies the excess amount of work which is w_{net} for doing some useful thing maybe generation of electricity. Then the low pressure low temperature gas that passes through another heat exchanger where heat is rejected and it comes back to its temperature at the beginning of the cycle that is at state point one and again goes to the compressor.

So, this is what a basic gas turbine cycle and this cycle is called a Brayton cycle or Joule cycle. As I have told for standard cycle we are assuming that heat is being added in a heat exchanger to heat the gas and heat is being rejected from the exhaust gas from the turbine.

(Refer Slide Time: 11:17)

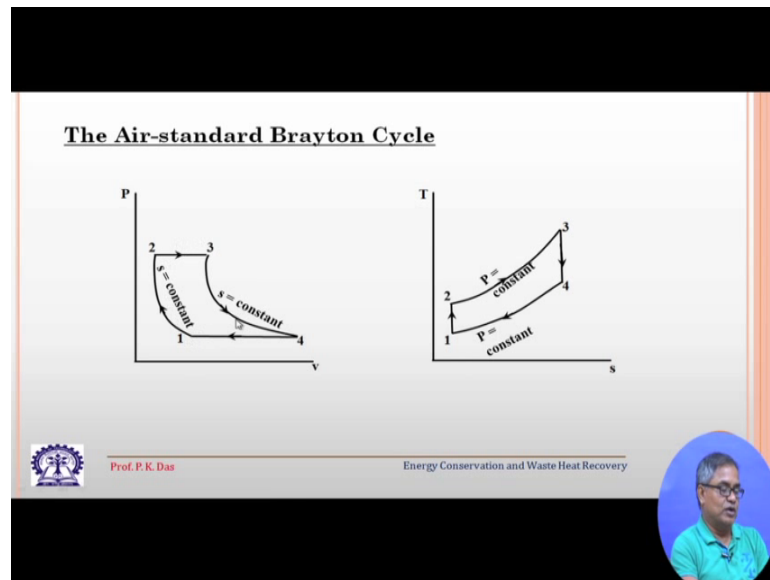

Next, if we think of the cycle diagram. The cycle diagram looks like this I have shown the cycle diagram in two different thermodynamic planes in P v plane from 1 to 2, there is rise in pressure. Basically, this represents the process in the compressor, then 2 to 3 heat addition at constant pressure, then there is expansion that is from 3 to 4 both the compression and expansion for an ideal cycle they are assumed to be isentropic or reversible adiabatic process.

Then 4 to 1 that is the heat rejection at the at another heat exchanger the exhaust gas from the turbine will reject heat and again it will come back to point one the cycle will continue. The T s diagram of the same process that is shown. The feature of this cycle is that the expansion and compression processes are isentropic processes, but the heat addition process and heat rejection process are constant pressure processes.

(Refer Slide Time: 12:46)

The efficiency of the air-standard Brayton cycle is found as:

$$\eta_{th} = 1 - \frac{Q_L}{Q_H} = 1 - \frac{C_p(T_4 - T_1)}{C_p(T_3 - T_2)} = 1 - \frac{T_4(T_4/T_1 - 1)}{T_2(T_3/T_2 - 1)}$$

$$\frac{P_3}{P_1} = \frac{P_2}{P_1}$$

$$\frac{P_2}{P_1} = \left(\frac{T_2}{T_1}\right)^{\frac{k}{k-1}} = \frac{P_3}{P_4} = \left(\frac{T_3}{T_4}\right)^{\frac{k}{k-1}}$$

$$\frac{T_3}{T_4} = \frac{T_2}{T_1} \quad \therefore \frac{T_3}{T_2} = \frac{T_4}{T_1} \quad \text{and} \quad \frac{T_3}{T_2} - 1 = \frac{T_4}{T_1} - 1$$

$$\eta_{th} = 1 - \frac{T_1}{T_2} = 1 - \frac{1}{(P_2/P_1)^{\frac{k-1}{k}}}$$

Prof. P. K. Das

Energy Conservation and Waste Heat Recovery



So, with this if we like to calculate the efficiency of the air standard Brayton cycle. So, the thermal efficiency that is 1 minus the heat rejected at the low temperature show or sync divided by the heat supplied to the cycle Q H, Q L by Q H and both the processes are a constant pressure process.

So, C p into delta t that will give the heat rejected and similarly we will get the heat that is added and then we will get this kind of expression by some sort of manipulation. Then what we get that the pressure ratios in the cycle, let us go back to the previous this one; that in the compressor the air pressure is raised from P 1 to P 2 after that there is a constant process a constant pressure process. So, P 2 is equal to P 3, then in the turbine the gas is rejected from P 3 to P 4. So, essentially we get P 2 is equal to P 3 and P 4 is equal to P 1.

So, exploiting this fact one can write P 3 by P 4 is equal to P 2 by P 1 and then for air standard cycle, we assume the gas behaves like an ideal gas. So, between pressure and temperature we have got this kind of a relationship and then for different temperature we can get find out some sort of a relationship like this and following the same procedure which is outlined in all the books of thermodynamics we can get the thermal efficiency in terms of pressure ratio and the constant k.

So, pressure ratio let me tell you what is pressure ratio? Pressure is raised from P 1 to P 2. So, P 2 by P 1 is called the pressure ratio of the cycle. So, in terms of pressure ratio,

we will get it and then there is another term which is k ; k is basically C_p by C_v and for ideal gas we can know; what is the value? if it is a diatomic gas it is 1.4. So, with this we will have the cycle efficiency. So, you can see the cycle efficiency is dependent only on pressure ratio. This we can replace by pressure ratio which is in most of the thermodynamics book which is denoted by r_p .

So, thermal efficiency is dependent on the pressure ratio and k ; k is C_p by C_v .

(Refer Slide Time: 16:20)

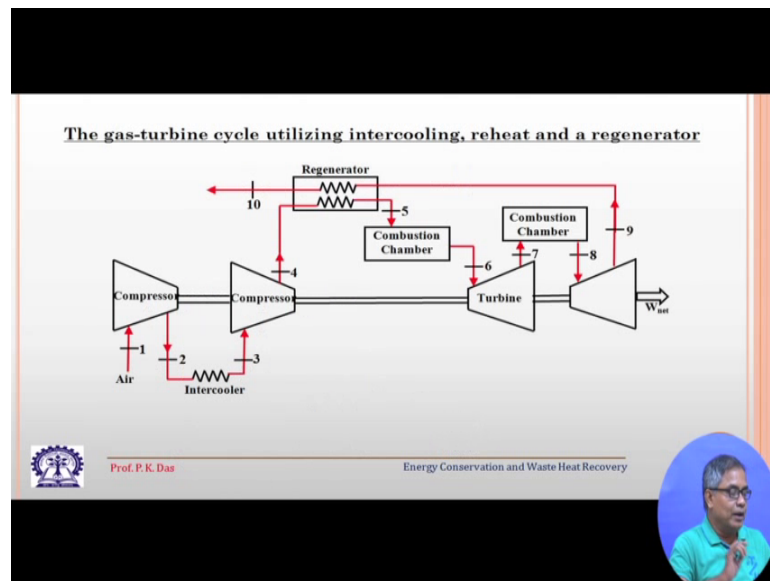

With this we come to the next figure. As we have told in the beginning, let us go back a few slides.

(Refer Slide Time: 16:34)

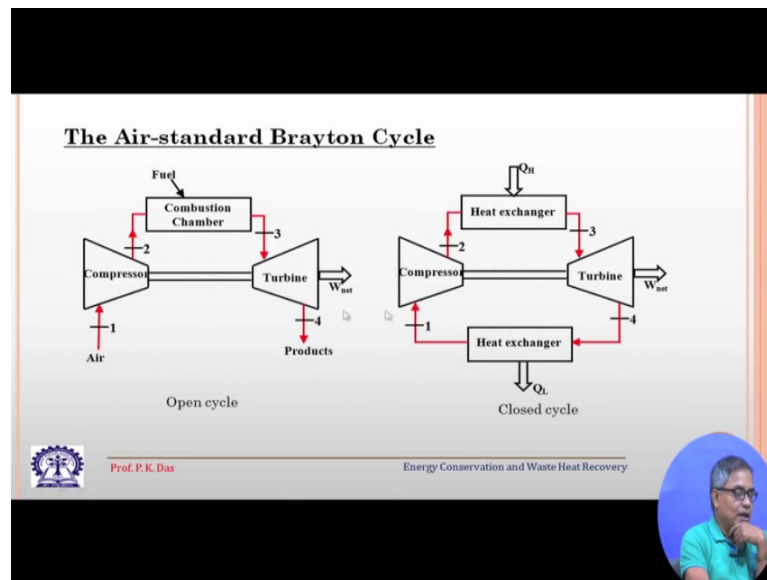

So, here though this is the ideal cycle the actual cycle is like this open cycle actual cycle is open cycle and most of the gas turbine operates in open cycle. There are certain example of closed cycle those are not many. So, this open cycle what we can find that from the turbine the exhaust gas that is coming out and that will have enough amount of thermal energy that will have enough amount of thermal energy and; obviously, it is going to the ambient atmosphere and it is a potential loss of energy.

So, once we appreciate this. So, there should be some way of recovering this energy and that is what is done by modifying the air standard Brayton cycle. Let us go back to the diagram which we have seen, but we can now explain it what is happening it is like this the exhaust gas which is coming out that can be used to heat the incoming air before it goes to the combustion chamber. So, basically here I have shown three devices which are used to or other three principles which are used to modify air standard Brayton cycle. So, that we will have better conversion of energy better utilization of energy and we will have a higher output from this cycle.

So, first is like this is what I have explained, but before that there is another principle which we have used. It is like this that air we have to compress and more it will be compressed better it is because, then we will have high amount of high energy because we have seen that the sorry greater efficiency of the cycle, because we have seen that the efficiency thermal efficiency of the cycle is dependent on pressure ratio more the

pressure ratio higher will be the cycle efficiency, but more the pressure ratio there will be more work needed by compressor and in the compressor we are compressing a gas compression needs external work, but the gas compression becomes more and more difficult as we compress it. Further compression becomes difficult why? Because, as we compress gas the gas temperature also increases the temperature of the gas that also increases and it is difficult it becomes difficult to compress a hot gas and that is why we will have progressively more work we will require progressively more work to have high compression or to have a high compression ratio.

So, what we can do the compression can be done in number of stages. Here, I have shown two stages initially gas will be compressed to certain pressure value its temperature will increase, then if we cool the gas and in the next stage if we compress a low temperature gas then we will have spending the same amount of work we will be having a higher pressure ratio or our work required by the compressor will decrease.

Now, what happens when we have it is a very important to appreciate one thing that we have seen earlier the Rankine cycle. In Rankine cycle also fluid pressure is to be increased and there we are having a pump. In case of gas turbine cycle here also the pressure is to be increased here we are having a compressor. In Rankine cycle we compress a liquid we need very small amount of work sometimes even that work of pump is neglected, but in case of Brayton cycle we compress some sort of a gas which is a compressible fluid and here we require very large amount of work to compress; unless our compressors are well designed unless we take care of the compression work by intercooler etcetera our gas turbine cycle will not be competitive one it will not produce much energy.

The energy which will be produced by the turbine much of heat will be consumed by the compression so intercooling is important. Then intercooling means when we are compressing the gas we are having it in different stages and in between we are having cooling. Similar principle applies in case of expansion, what we do? In the basic Brayton cycle we heat the gas in the combustion chamber or in other case in some heat exchanger and after that we let it expand in a turbine.

Now, when we are letting it expanding in a turbine in the basic cycle it has been shown that the expansion is done in one turbine in one stage, but if we can do it in a number of

stages; that means, the gas will be expanded up to certain point, then its temperature will be increased again by providing let us say another combustion chamber and burning some more fuel. So, the expansion will also be done in stages in between we will have heating so, we can extract more work; efficiency plant efficiency that will go on increasing. And ultimately after that what we are doing when exhaust gas is coming out of the last stage of the turbine that exhaust gas will have thermal energy and that we are utilizing in a heat exchanger to heat the gas which will come out of the final stage of the compressor.

So, that hot gas goes to the combustion chamber and the combustion efficiency increases. We have to supply less amount of fuel in the combustion chamber to have the same amount of energy, because part of the energy we are utilizing from the hot exhaust gas. So, for a gas turbine cycle utilizing intercooling reheats and regeneration we can increase its efficiency. So, basically then we will find that rarely when a gas turbine power plant is being utilized as a standalone device; rarely we will use a normal basic gas turbine cycle or the initial return cycle initially the Brayton cycle which we have shown we will have cycles with some sort of modification and basically these three modifications are considered; one is your inter-cooling between different stages of compression and then heating reheating sometimes it is also called this also called reheating; reheating of the gas after first stage of expansion or after some stage of expansion. So, reheating and then some sort of heat exchange by through a recuperator or some sort of regenerator whatever; we could use and heat the gas out of the final stage of the compressor before it goes to the combustion chamber.

The basic cycle diagram which we have got, I will just take small amount of time to explain this; the basic cycle diagram which we have got is like this.

(Refer Slide Time: 26:34)

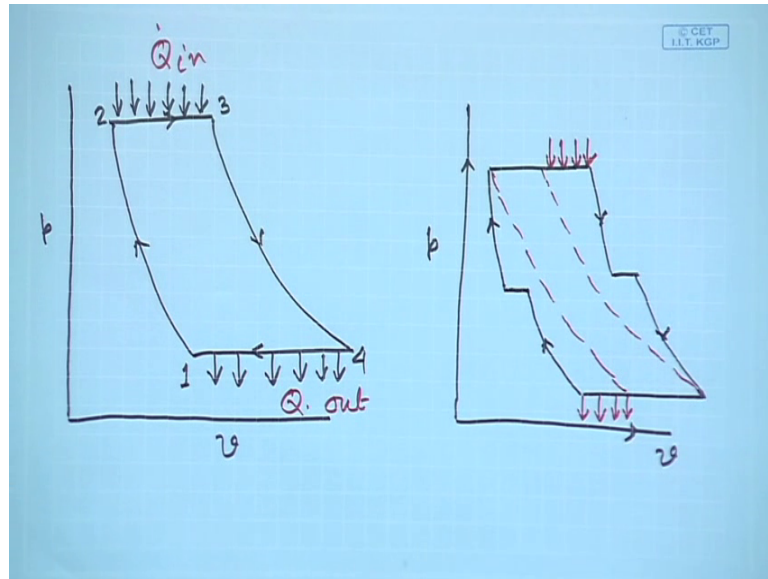

Let us consider the p v diagram. So, this is the basic Brayton air standard Brayton cycle 1, 2, 3, 4 we have got. And, here you see this is your Q_{in} and this is your heat rejection or Q_{out} .

Now, with these modifications, what we will get is like this is the first stage of compression, then there will be some sort of intercooling and then there is next stage of next stage of compression and then this is the constant pressure heat addition. This is the first stage of expansion then reheating then the next stage of expansion.

Now, the amount of heat which is rejected part of it will now be taken to heat the air which is coming out of the compression final stage of the compression. Then only this much amount of heat we are adding in the combustion chamber or rather from an external source. So, this is just like before p v and then we are also rejecting less amount of heat; so, this; obviously, increases the thermal efficiency of the cycle. So, basic cycle and some modification of the Brayton cycle that we have discussed, based on that we will be able to produce a sorry we will be able to proceed to the concepts where the energy conservation principle and waste heat recovery principles are very important. So, with this I like to thank you all. And this is the end of our discussion on the gas turbine cycle.