

**MEMS & Microsystems**  
**Prof. Santiram Kal**  
**Department of Electronics & Electrical Communication Engineering**  
**Indian institute of Technology, Kharagpur**  
**Lecture No. #31**  
**Interface Electronics for MEMS**

Today's topic of discussion is interface electronics for MEMS. In last few lectures we have discussed on MEMS devices, particularly micromachine microsensors. And one of the basic jobs of micro mechanical system is that it is a combination of sensors, actuators and signal conditioning circuits. So if you do not think of the signal conditioning and signal processing circuits then the complete the system is or micromechanical system configuration is not complete. So we have to see what are the various aspects of the output signals coming from the transducers and how do you proceed with those signals before processing and after processing. How those signals are fed to actuators for further function functionalization or for further action. Thus the interface electronics is an important aspect of any of the micro system and at the moment lot of work is going on. This important topic which is interface electronics. Now the signal which is received at the output of the microsensors is of particular characteristics. Because of the different nature of the signal obtained at the output of the microsensors, its signal conditioning circuits and will be different.

And in most of the cases the signal processing part we preferred to have digital component digital signal and we are incline or we love to process the signal using microprocessor or micro controller or in a computer. So there you know the only signal which is digital that can be processed. But sensors signals are not digital in nature. So that is the reason we have to go for some conversion also after getting the signal from the output of the microsensor. It has the condition and then you have to change the analog to digital before further processing with the help of either micro controller or microprocessor and the output are taken and then they will control the actuators and other things. In fact this particular area is not widely explored till now, although the microsensor has reached a certain level at the movement. But signal conditioning circuits is not yet fully matured. So what are the problems, those will highlight now and will try to solve some of the problems.

(Refer Slide Time: 04:16)

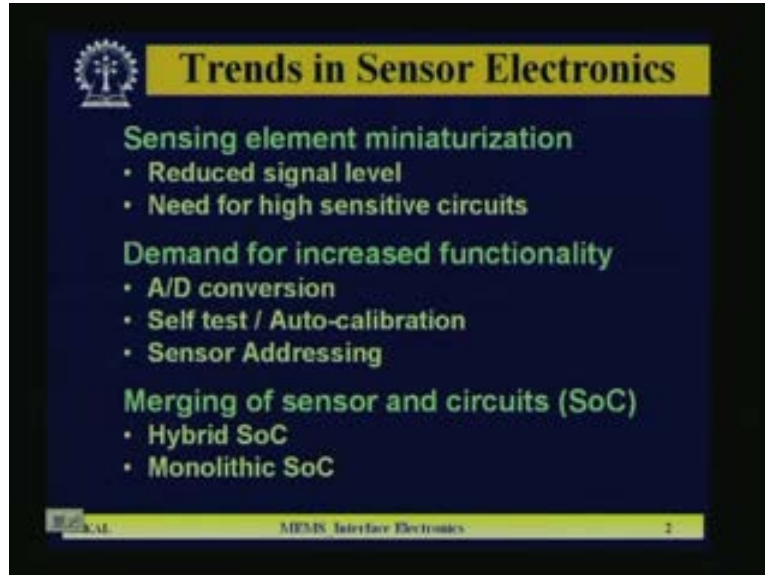

Here the slide you can see the trends of the sensor electronics. We know the sensing element means microsensors are miniaturized day by day and at present due to the micro miniaturization the sensor signal output level is very small. It is in the range of micro volt or mini volt or if its output is current, then some cases microampere, nanoampere any in some cases picoampere also. If it is a capacity the changes in the range of the picofarads, so since the change is negligibly small. So obviously there is a problem of the sensitivity. Because if this signal output from the microsensors are extremely low, so it is very difficult to the person to distinguish between which is the signal and which is the noise. Because any of this system will have noise fluctuations and those noises coming from different reasons. May be the device noise, may be the thermal noise, and may be the electromagnetic interaction noise. So different kinds of noises are there and we know the noise signals are also small in amplitude.

So because of that you need a very high sensitive circuit so that you can extract the signal which is basically coming due to the input variation of the sensor and you are not interest with the noise. That is one of the major problems of the signal conditioning of microsensor. Second is day by day the functionality are in are getting more and more complex. We demand for increases functionality because we think it should be smart. If a microsystem is smart if a microsensor is smart then its functionality will be more and more. And because of the demand for increased functionality lot of other things are coming into the picture. Namely AD conversion analog to digital conversion because we love to process the signal at the end in digitally. Second is self-test and auto calibration. Self-test in auto calibration means many of the micro system they need auto calibration because which time the calibration may change because of the drift or other reasons.

So in that we want your device should be calibrated automatically self-test so those are the added function which were not there at the beginning and if you want to incorporate those aspects into the microsystem, so obviously the electronics part become more and

more complex and the sensor addressing. This is another point because if you will multiple sensors for different activity in a microsystem. Microsystem does not contain only one sensor, may be multiple some sensors are various kinds are attached with the system at different locations. So we have to address the proper sensor at the proper time. So that is another question which you have to address because in a multifunction multiple sensors you have to address proper kind of sensor in proper time. That is done only with the help of electronics. So that also is a part of interface electronics. So because of all those demands gradually the miniaturization and the increase functionality are complexing the complete situation and lastly people are now thinking of SoC.

What is that? System on chip. On a single chip they want the complete system either hybrid or in monolithic version. There are two kinds of SoC; one is known as the hybrid SoC and another is known as monolithic SoC. The whole system if you want to have a small chip. So obviously complexity will increase further. So the trends of the recent sensor electronics have made the interface electronics more complicated. That is why in many of the systems may of the sensors will found that this for particular part the interface part is a still in many cases. It is the foggy area there is not clear picture available and work is going on. In some cases we have identified some of the solutions and in some cases we are yet to identify the solution.

(Refer Slide Time: 09:59)

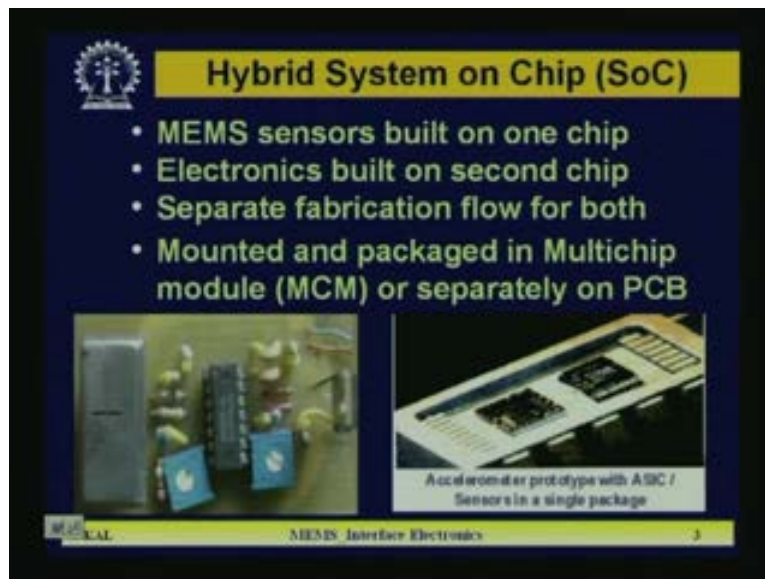

Now in this slide you can see some of the pictures also. That is system on chip SoC there MEMS sensor built on one chip, electronics built on the second chip is on possibility. Electronics part you built on the second chip and MEMS sensor you built on the separate chip. Now what you can do? Both the chips the MEMS sensors and electronics, both you can integrate together. That is known as the multiple modules or MCM or it is also some kind of SoC mounted and packaged in multichip module which is known as MCM or separately on PCB. Both the pictures are shown; both are hybrid. So in the right side what we can see is a, this is the basically the multichip module. One chip is a sensor chip and

the other is the electronics part. The sensor and electronics part, they are coupled inside the chip. So it is basically system on chip; but it is multiple moduled. And other one is known as the hybrid mode. There the sensor part is here. For example this is on accelerometer and others are the different components which are connected on a PCB to get the interface electronic circuit.

So these kinds of things are known as hybrid complete hybrid mod on a PCB. But people prefer this MCM package which is much more miniaturized and there you can get much more precision. Because you know if you go for hybrid for simplification of the technology or simplification of getting the package but the problems are manifold. Particularly as at the beginning I mention people are much more causes on the noise part and some of the noise pickup will be coming from the parasitics and in the hybrid package more lot of parasitics will be there which are not directly seen some are visible and some are not visible. So because of those things, so some other pickups will be there which may confuse your actual signal which is coming from the microsensor. So if you go for a real multichip module then technology is little bit tougher than hybrid on PCB. But if you go for SoC, real SoC or monolithic is still much more difficult.

And then one of the problem lies there is the technology should be highly compatible your MEMS technology should be highly compatible with the VLSI technology. Because we are integrating your micromachining and micro sensor fabrication steps along with the VLSI processing. So there some of the restrictions are mainly you cannot go for long time etching that is which is required in case of bulk micromachining. Mostly you have to go for surface micromachining and there again you have to see the complete process steps which will not deter the other part also. So that is why the complete monolithic version of the system on chip still now is occupied by few companies and in majority of the founded houses or majority of the chips are coming which is the SoC. But it is in the hybrid form, either on a PCB or in MCM; mostly it is MCM.

(Refer Slide Time: 14:13)

**Hybrid System on Chip (SoC)**

- MEMS sensors and actuators are built on same monolithic substrate
- Small cost-overhead for added electronics
- Less effects for interface parasites
- Flip-chip, monolithic integration bonding

Pressure Sensor Prototype

MEMS: Interfac Electronics 4

Now hybrid system on chip, one thing here you can see as I told you, here both the pictures are the either MCM or system on PCB. But that next diagram which you can see here is basically, it is in the system on chip which is interconnected the sensor and the circuit monolithically and here both actuators not only sensor is microsystem ULT because it is known as system. System means it may be included the actuator part also. Sensor circuits and actuators both are integrated in this particular and a precession of prototype is shown here. That is the real monolithic version of SoC. Now people are also concerned regarding the small cost overhead for added electronics. That is one issue because if you add electronics unnecessary, if you increase the cost, so you will not get the good market. Second is less effects for interface parasitics.

This is also another concern you should a go for certain things which is not, which is free from the interface parasitics elements and third, the flip-chip monolithic integration bonding. That is another concern, if you have both integrated either monolithic or hybrid you have to look into the bonding and integration part also. Because packaging and bonding part takes the major share of the cost of any of the chip. So that is why if the bonding and packing part is much more expensive. If you go for miniaturization or the SoC is made monolithically then you have to think before you go actually from the cost calculation point of this. Now these are the issues which one should address before going for the system on chip.

(Refer Slide Time: 16:30)

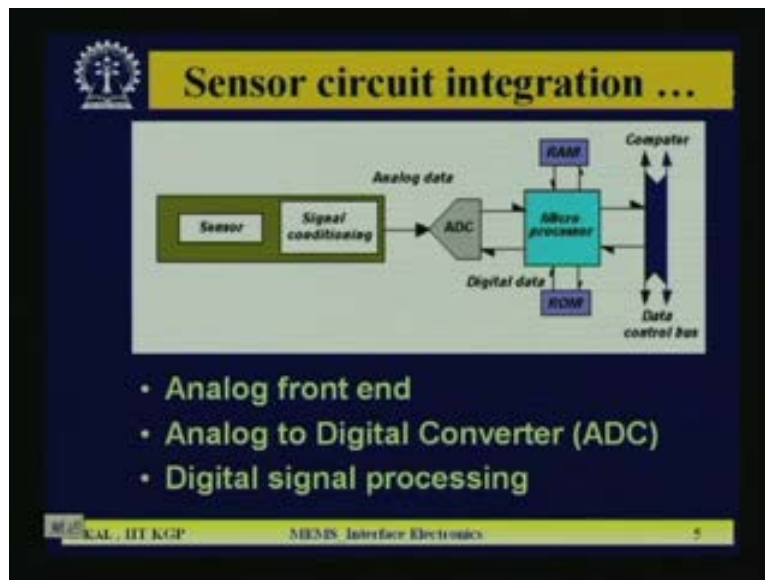

Now let us come to sensor circuit integration. What are there in sensor circuit integration? There first the sensor will be there, then signal conditioning circuit and which is just after immediate after the sensor. Then you will get the analog data and this analog data must fade into the ADC which will give you the digital output and this digital data now you can safely process in a microprocessor along with RAMs and ROMs will be there. And then you can have some computer, you can have lot of control databases

from which you can feed the data to other subsequent module or it can go to any of the actuators for controlling purpose. So this is basically the complete a picture where you have several blocks. First one is analog front end which is the first block is analog front end. Then is analog to digital converter what the ADC is then comes digital signal processing. You can connect directly here, a DSP chip also for further processing you have signal and then another electronics blocks will be there for controlling part also. That is basically may be some actuation of the system which you want to do. So these are the three pieces; out of the three pieces, the first piece is the analog front end.

(Refer Slide Time: 18:02)

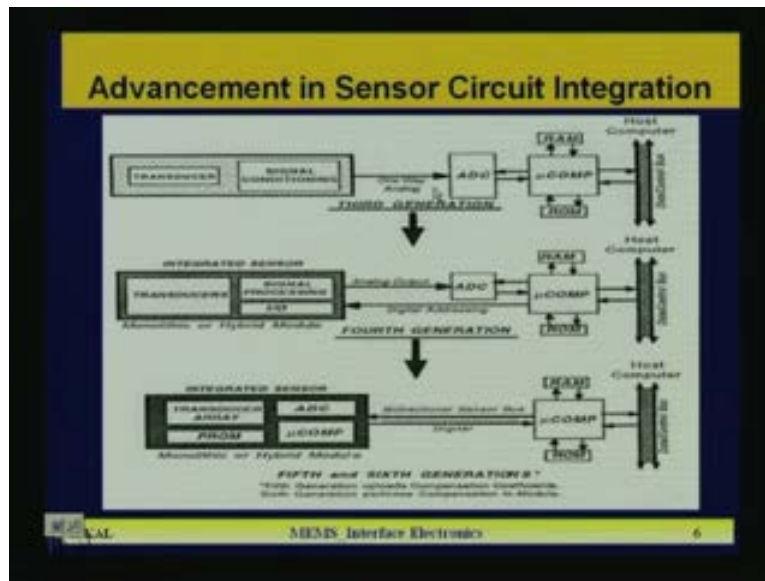

So the analog front end lots of things are going on. Now just I mentioned that the demands of the people are going high day by day. So that is why the sensor circuit integration is evolving new dimension day by day. That is why the lot of blocks are coming which are know as third generation, forth generation, fifth and sixth generation. The sensor circuit integration basically what are those. If you look into this picture then it will be clear, you can see here in the third generation basically you start from. So first second we are not talking about. That is the bulk age the heavy sensors and heavy circuits and they are connected by wires in a hybrid board something like that. That we are not bothered at this moment in the MEMS and microsystem error. So in the third generation where you can see the transducers and signal conditioning.

Nothing else in the first block and the one way analog there is no two way business here. Then it comes to ADC and then micro computer which is connected to RAM or ROM and then you say computer and data have which is basically the third generation diagram you shown in the earlier slide same as the earlier slide. Now in the third generation to fourth generation, what are the modifications? You can see here in the fourth generation people like to have both way interactions in the analog. You see here from the micro computer when ADC is put in the microcomputer, there are also some part of the signal is coming at the integrated sensors. That means the analog front end here. Here also you can

see transducer then signal processing not signal conditioning these are events. First one is signal conditioning, then second diagram which is fourth generation is a signal processing.

Signal processing means all these blocks are included here. So then it will have IO inputs also. From the IO inputs so basically from there is a direct interaction between your microcomputer again. So that means this is the fourth generation where you have the access of putting them output or some of the signal from the microcomputer back to the front end circuit. Obviously if you add this to the front end with the sensor input signal it has to be converted into again analog. So that is not shown here, some IO is shown. But next part is the fourth generation to fifth and sixth generation the sensor circuit integration. Here you can see the first module has been changed completely. So there a not only integrating transducer, but transducer arrays not a single sensor array of transducer. That mean here coming into picture sensor addressing, so that part will be there, ADC is there, microcomputer is there, PROM is there.

That means what is there in the fourth generation, whole thing came into one module and that is the integrated sensor which itself is smart. Then again by directional sensor bar is there and there the communication will be there with again computer and from this computer it goes to the host computer. So that means it is further refined and since in the first block, all the blocks in the third and fourth generation are integrated. So the chip of the fifth and sixth generation, the front end will be much more complicated and it will be highly expensive also and challenging to get this kind of the conditioning or the interface electronic circuit.

(Refer Slide Time: 22:17)

Typical transducer characteristics	Challenges	Desired system characteristics
$\mu\text{V}$ range output	Low offset and Noise	Voltage-level signals output
Parts-per-million changes (mV, fF)	Onchip analog interface	Amplified and buffered outputs
Analog signals	In-module ADC	Digital signals
Cross parameter sensitivities	Sensing of secondary variable	Pure parameter measured
Individual device outputs	Embedded Microcontroller	Multiplexed and addressable
Offset/ slope/ Linearity problem	Compensation standards	Digitally compensated
Output drifts over time	Stable references in module Actuators	Self-testing remote calibration

MEMS: Interface Electronics

Now role of interface electronics so integrated MEMS sensor. As I told you there are lots of characteristics of the signal received from the output of the microsensors. What are those characteristics and what are the challenges, so that you can go ahead with those

signal conditioning or interface electronic circuit. Number one is that the output is micro volt range of because it is not written in the micro farad or microampere or pico ampere. Actually for processing whatever the signal output we get from the micro sensor, we can convert to a voltage. So that will be very easy for further processing. That is why it is written only in the microvolt range. So outputs of the sensors are always in the microvolt range and those sensors, the problem if it is a microvolt, then what the challenges a low offset are and low noise. So offset will be there that will be again in many of the sensor it is a microvolt range and noise that also in the microvolt range.

So if both are noise offset and here was basic signals are microvolt range then this is the problems how to tackle them. These are system characteristic voltage level signals output. That is I have mentioned that people always perfect have voltage levels rather than current signal or some change of capacitance or change of resistance in ultimately we convert into the change of voltage. Next is the part per million change ppm changes micro ohm or femto farad. So changes with the input variation of the measurand will be in the range of ppm level in many cases. And that ppm level change has to be reflected at the output. So people prefer for that on-chip analog interface, not the ppm level change. If it is taking the sensor and with the wire if you connect with your amplifier or other things, then the problem comes is again, so you cannot see the effect of ppm changes. So you need on-chip analog electronics and system should have amplifier and buffer output amplified and buffer output should be there.

Next one is analog signals. Then these are the characteristics analog all the signals mainly received from your output of the microsensors are analog in nature. In module ADC is required. But characteristics ultimately for processing should be digital signal. That is why we are connecting ADC. Cross parameter sensitivities is the major issue. Cross parameter sensitivity means your sensors are intended to a sense the variation of the measurand at the output, at the input which will be reflected at the output. But your intended measurand there are some secondary effect which can change your output of the sensor also. For example a sensor in case of piezoresistance say pressure sensor the piezoresistance can change with pressure. That is the intended variation, but this piezoresistance can change with temperature. This is the second way effect. That is known as the cross parameter sensitivity.

Your sensor should not be highly sensitive with the temperature variation. Although it is there, you have to take care at the circuit level. So that the secondary parameter variation is not reflected at the output of the sensor. So that is the cross parameter sensitivities. Sensing of secondary variables, how can you check it? You have to sense the secondary variables and the secondary variables should be minimized or should be deleted at the output of the complete front end analog system. Now pure parameter measured, you should get the actual value of the pure parameter which you are looking for. Now individual device outputs. So in case of multiple sensors connecting, so you are interested the individual device output in a system. So there may be lot of sensors with different nature. So they should not be cross connected cross related. One sensor output cannot be interrupted by the other sensor output.



That is why individual device output should be separately sensed. Embedded micro controller is some of the solution, but is a real challenge to have. Multiplex and addressable. So that is another issue where you are working with is a multiple multifunction sensors in a micro system. Next is coming offset slope and linearity problem. These are the inbuilt problem of any kind of sensor, offset will be there. Linearity is not is always, it is a desirable property of any sensor, but all the will have some non-linearity. So that how to get read of that problem and for that you have to have compensation standards should be there and the people prefer for compensation digitally. Output drifts over time that is another thing. Last one is output drifts over time. So that is the sensor drifting that we know with time because of the aging.

So the calibration of the sensor may change and the output may be drifted, may be changed. So to reduce that change or the aging problem, compensation can be done with the help of stable references in module actuators. Self-testing removed calibration. So that is because some of the sensors which are already fixed and which we do not have access directly. So how can you correct them, so that is why people are thinking the testing of the sensors could be done automatically and remotely. Remotely it can be calibrated also. So that means these are fifth and sixth generation microsystem sensor circuits which are really challenging task. Now, I am but people are working for it, obviously solutions are coming and will come in future. Now sensors signal conditioning which we talk about this is analog front end.

(Refer Slide Time: 29:41)

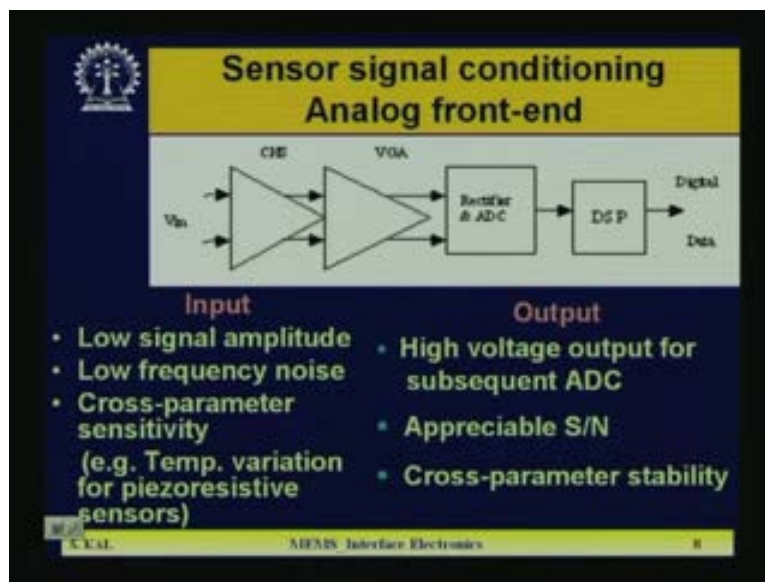

So analog front end the input and output. There is the first block there low signal amplitude low frequency noise and cross parameter sensitivity. These are the input there are 3 issues we have to remove. Output we need what? High voltage output for sensing, subsequent ADC appreciable signal to noise ratio cross parameter stability. These are our requirement by inputs are problematic because they contain the low amplitude signal low frequency noise. So this is one of the important aspects of any of the sensor signal. So in

the low frequency noise are included into the sensor actual signal and how to get read of that. So there the inputs are fed first you have to do. What you have to do? You have to pass the signal into an amplifier. Because first step to raise the signal level before further processing and then what kind of amplifier will choose which will give you better low frequency noise as well as the drift so that we have to look for. So that amplifier then goes to some ADC or some filter and then go the ultimately it will go to DSP.

(Refer Slide Time: 31:17)

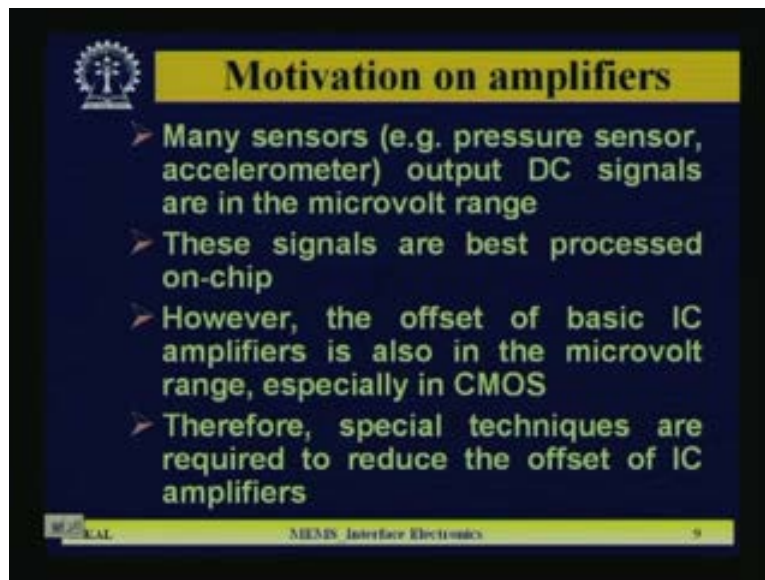

The slide features a dark blue background with a yellow header bar containing the title "Motivation on amplifiers". To the left of the title is a small circular logo with a gear and a figure. Below the title, there is a bulleted list of four points in yellow text. At the bottom of the slide, there is a yellow footer bar with the text "MEAS Interface Electronics" and a small number "9" on the right.

- Many sensors (e.g. pressure sensor, accelerometer) output DC signals are in the microvolt range
- These signals are best processed on-chip
- However, the offset of basic IC amplifiers is also in the microvolt range, especially in CMOS
- Therefore, special techniques are required to reduce the offset of IC amplifiers

Now motivation on amplifiers as the immediate block of any micro sensors is amplifier. So what should be the motivation for selecting the amplifiers? Many sensor particularly pressure sensor and accelerometer output DC signals are in microvolt range. Signals are DC and microvolt and these signals are best processed on-chip. However the offset of the basic IC amplifier is also in the microvolt range especially in CMOS. So special techniques are required to reduce the offset of IC amplifiers. So this is one first objective to choose an amplifier which will have minimum offset.

(Refer Slide Time: 32:12)

### Differential Amplifiers

Differential amplifiers are widely used to amplify DC signals

Balanced structure is ...

- Nominally offset free
- Rejects common-mode and power supply interference
- Easily realized in both CMOS and bipolar

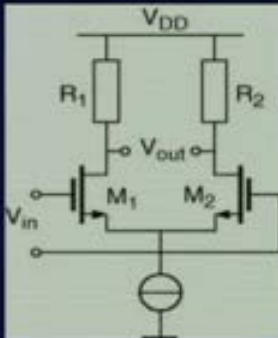

MEMS Interfac Electronics 10

So in that respect we know the differential amplifier configuration is the best choice. So for a sensor amplifier people preferred or widely used the differential amplifier which can amplify DC signals also. So why this structure is balanced in all differential amplifiers is balanced structure and circuit is shown here this is a mass differential amplifier. So here normally since the structure is balanced, so it is offset free. It rejects common mode and power supply interference also. Easily realized in both CMOS and bipolar. In both technology, both CMOS and bipolar you can make this kind of amplifiers easily.

(Refer Slide Time: 33:12)

### Offset in Differential Amplifiers

Component mismatch → Offset

Mismatch is mainly due to.....

- Process variation
- Lithographic errors

All other things being equal:

Bipolar →  $V_{OS} \sim 0.1\text{mV}$

CMOS → 10 – 100 times worse!

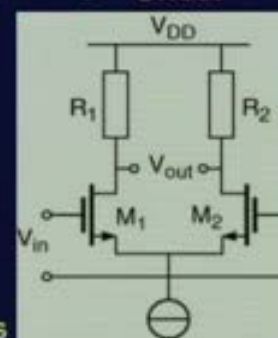

MEMS Interfac Electronics 11

And how we get the offset? Offset is basically due to the component mismatch. Although it is a perfectly balanced structure in differential amplifier. But you have seen here M1 M2 and R1 R2, these are the components. The M1 M2 should be perfectly matched pair. If it is not matched, so obviously is likely that you will get some offset also. So in that case this un-matching of the components is coming due to the process variation. Although in the design level both M1, M2 are perfectly matched in simulation level. Also you can check it is perfectly match. But in reality when you get the chip if you test it, then there may be some mismatch and because of that you are getting the offset and that mismatch is the contribution of the process variation and the lithographic errors when you go for the photo masking. So because of that may be in some level, some of the area of the active devices either the gate area or the oxide thickness on that gate, so those things may change little bit due to the process variation and because of which you can get some offset. In case of bipolar, this offset voltage is nearly of the order of 0.1 millivolt. But in case of CMOS it is much worse near 10 to 100 times in some cases compared to the bipolar devices, bipolar differential amplifier. So these are some of the points when you address these low offset you should think not only in the design but also in process side of the VLSI technology steps.

(Refer Slide Time: 35:16)



The slide is titled "Drift and Noise" and is set against a dark blue background with yellow text. It features a small logo in the top left corner. The content is organized into two main sections: "Drift" and "1/f (or flicker) noise".

- Drift**
  - Temperature, aging and packaging stress cause time-varying offset
  - Trimming bipolar DA's reduces both offset and temperature drift. Not true of MOSFETs !!!
- 1/f (or flicker) noise**
  - MOSFETs are worse than bipolar transistor
  - Varies inversely with transistor area

At the bottom of the slide, there is a footer with the text "MISIS: Interface Electronics" and the number "12".

Now comes drift, so that is offset which I talked about now the drift. Drift is basically due to temperature aging and packaging stress cause time varying offset. So the package which are used if stress is generated, because as I told you in the last lecture when bonding and packaging class. So there because of various layers are bonded together, so there is a probability of stress on the active elements on the devices because of the mismatch of the thermal expansion coefficients and other parameters. So that can because if there is a stress and that will be reflected in your device and for that you can get some change of the signals which is known as the aging or temperature drift. And how can you reduce that? You can trim. In case of bipolar there are different the associated components are there. They can be trimmed and according of the external trimming can

change the, can compensate the drift and offsets also. But is very difficult to that, to adopt that technique in case of MOSFET. Third one problem is frequent noise. Frequent noise is basically the 1 by f noise which is coming in the low frequency arena and there one has to check how the 1 by f noise or frequent noise should be controlled. How it can be controlled? MOSFETs are worse than bipolar transistors in case of the frequent noise also. That is inversely with transistor area.

(Refer Slide Time: 37:18)

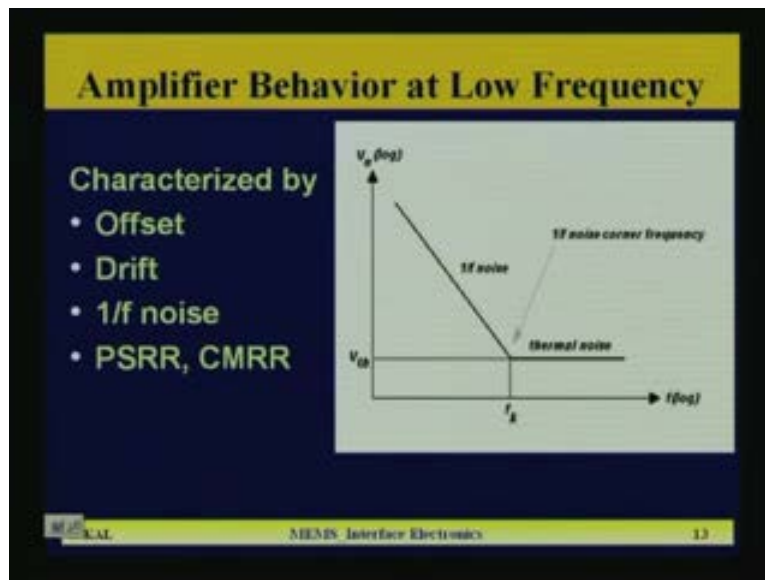

This frequent noise, now this diagram shows the two noise how it varies with frequency and what are their magnitude. The diagram here you can see it is, plot is up the frequency versus the noise voltage; both are in logarithmic scale. Then you can see at very low frequency 1 by f noise is very high. Noise voltage is very high and if you go and increasing the frequency it reduces and after that you are getting the thermal noise and this thermal noise  $V_{th}$  is frequency independent. But frequent noise is completely frequency dependent. Now because of the thermal noise the  $V_{th}$  you are generating that may also give you is a constant drift. So the amplifier behavior at low frequency is characterized by offset drift 1 by f noise CMRR and PSSR.

(Refer Slide Time: 38:25)

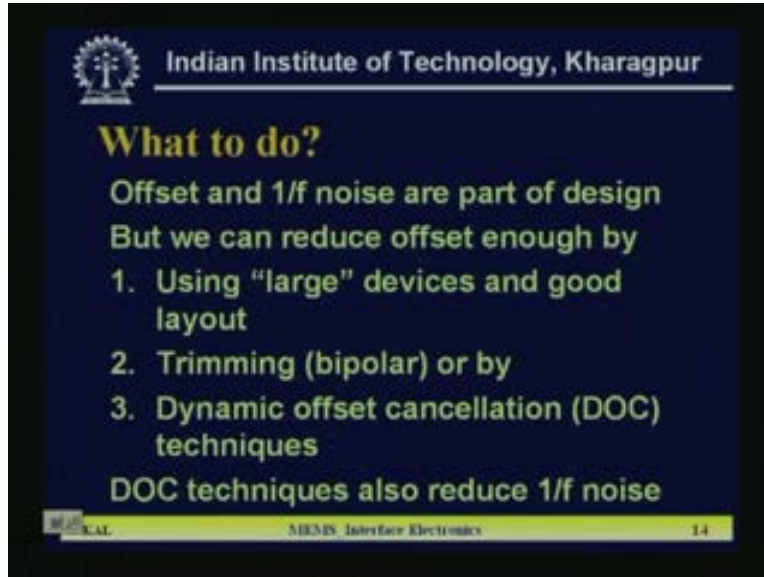

Indian Institute of Technology, Kharagpur

### What to do?

Offset and  $1/f$  noise are part of design  
But we can reduce offset enough by

1. Using "large" devices and good layout
2. Trimming (bipolar) or by
3. Dynamic offset cancellation (DOC) techniques

DOC techniques also reduce  $1/f$  noise

MEMS: Interfac Electronics 14

So these are the parameters which has to be properly adjusted and proper measures is to be taken when you are designing, those sensor interface electronic circuit particularly amplifier. Then what is the solution? Offset and  $1/f$  noise is part of design. But we can reduce offset enough by using large device and good layout. Those are one of the options, second option is trimming. Particular it is possible in bipolar or by DOC which is the dynamic offset cancellation techniques. That is one of the techniques which are nowadays used in many of the sensor signal conditioning circuits. DOC dynamic offset cancellation techniques. DOC techniques also reduce  $1/f$  noise. Not only the offset. Both offset and  $1/f$  noise both are drastically reduced by dynamic offset cancellation technique which can be used either MOS or bipolar in both cases.

(Refer Slide Time: 39:39)

Indian Institute of Technology, Kharagpur

## Trimming

External potentiometer

- Extra component and extra pins in IC technology
- Laser trimming
- Component switching
  - Zener zapping
  - Fusible links
  - PROM

Trimming → extra test infrastructure

IIT Kharagpur MIMS - Interfac Electronics 15

Now trimming. For the trimming what you need? You need an external potentiometer. What are the plus points and minus points of the trimming techniques to adjust offsets and other parameters, unreasonable parameters basically? Here you have to have an extra component and extra pins in IC technology which people do not want. It is an extra complexity is coming, extra component means they go for sometimes laser trimming. Laser trimming of the components are also available that technique some time they use that. But other trimming possibilities are component switching. Those are basically zener zapping fusible links and PROM. PROM and fusible links are basically used in many cases. Those are because there are lots of links connected with different components, so if you want to fuse those links, that means fuse and anti-fuse technology, for that you have to programming.

So something is increasing, so you can make your circuit in such a fashion by fusing some of the links you can disconnect that component. So you can have basically it is the some kind of trimming. That trimming is not done by potentiometer. That is not done by laser. But you can done by switching mechanism and that is one of the preferred techniques in nowadays in many of the sensor interface electronic circuits. You can trim the component to reduce offset as well as the drift by switching technique and that is the fusible links technique. You can disconnect or you can connect also. That is known as fuse and anti-fuse technology. So there also you can easily connect some of the resistance with some polysilicon links or polysilicon fuse and those fuses can be blown anytime by using some by using some signal of high current pulse. So that technique is also preferred technique for those cases.

(Refer Slide Time: 42:00)

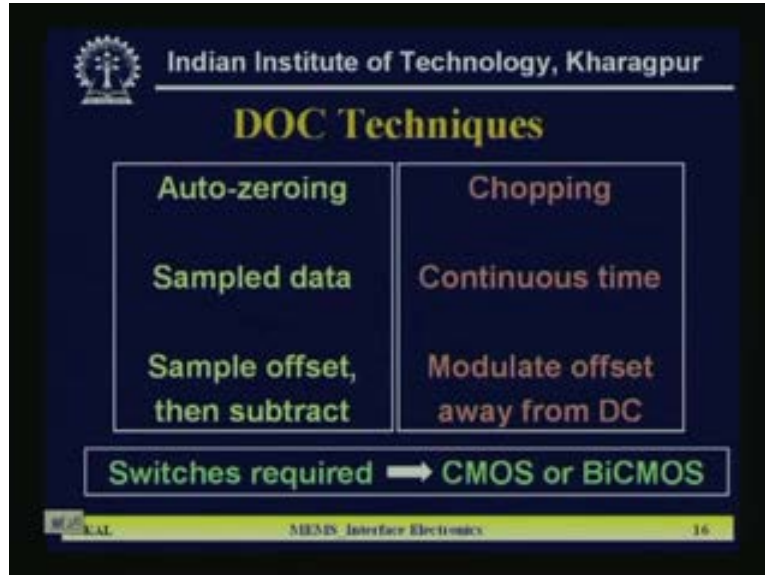

Now DOC techniques. Dynamic offset cancellation technique. So that techniques are auto zeroing. You need there sampled data sample you have to sample the offset and then you have to chop. These are the technique, one is the auto zeroing technique and there you need data is to be sampled and to sample the offset signal also then you subtract it. So for that case you have to chop. Chopping is included there, continuous time processing modulate the offset and away from DC. So offset signal you modulate it then you take it away from DC and then you can subtract it and then you can get rid of those things. This is dynamically done in the complete processor. Obviously it needs some switches and those switches are either CMOS or BiCMOS. Because CMOS BiCMOS one of the biggest advantage you know is the low power and highly integrable. So that is one of the drives in force behind those two techniques.



(Refer Slide Time: 43:15)

Indian Institute of Technology, Kharagpur

## DOC Techniques vs Trimming

- ▲ Reduction of offset and  $1/f$  noise
- ▲ Excellent long term stability
- ▲ No additional costs for testing
- ▼ Reduced bandwidth
- ▼ Increased circuit complexity
- ▼ Aliasing & intermodulation issues

MEMS Interfac Electronics 17

Now DOC techniques verses trimming. If you compare then the DOC techniques can reduce offset and  $1/f$  noise simultaneously. It has got excellent long term stability, no additional costs for testing. So this is the plus points of the DOC technique. On the other hand problems are here reduced bandwidth. Increased circuit complexity. Because you need lot of blocks. There we have to integrate monolithically. So increase circuit complexity. Aliasing and intermodulation issues, those are also required in case of the dynamic offset cancellation technique. In brief I will just give you some picture on the auto zero techniques.

(Refer Slide Time: 44:06)

Indian Institute of Technology, Kharagpur

## Auto-Zero Technique

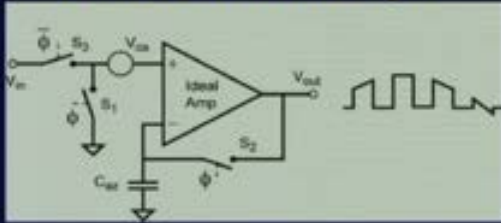

- S 1,2 closed → amplifier offset is stored on  $C_{az}$
- S 3 closed → output signal is available
- Residual offset  $\sim V_{OS} / A$

MEMS Interfac Electronics 18

And DOC means the chopper stabilization techniques. So auto zero technique here basically the input is coming here there are 3 switches viewed S1, S3 and S2 and this is an ideal amplifier. So what there this is basically they offset signal is coming here. So now initially you can connect the switches 1 and 2. This switch  $\phi$  and this is another  $\phi$  this switch S2 you connect it. Now they are no inputs are there whatever the offset because of the mismatch of the amplifier itself is coming. So those things are the offset is amplified and that is again stored into the  $C_{az}$ , this capacitor can store it here. In the next step you can just put the input signal and connect it there and you can subtract it and automatically in this way you can get adopt because output signal is something like that. So offsets are going to be reduced and automatically are going to close to 0. So this technique is used in many cases. Auto zero technique you at the residual of the offset which is at the end available, which will be reduced by the amplifier A which is the amplifier gain.

(Refer Slide Time: 45:30)

Indian Institute of Technology, Kharagpur

## Residual Offset in Auto-zero

Determined by.....

- Charge injection
- Leakage on Capacitor  $C_{az}$
- Limited amplifier gain & bandwidth

Practically.....

- $C_{az}$  is large (sometimes external)
- Multi-stage amplifier topologies
- $F_c \gg F_s$  (sampling frequency)
- Residual offset of 1-100  $\mu V$

ME6502: Analog Electronics

Now this residual offset in auto zero technique is determined by 3 parameters. One is charge injection, however the capacitance is main  $C_{az}$ . How you can charge the capacitance leakage on capacitor leakage should be as small as possible. So that total offset can be store there initially. Limited amplifier gain and bandwidth. These are the determining factors in this auto zero technique. Practically  $C_{az}$  is the large sometimes in order to have the three parameters which are intended charge injection leakage, low leakage and for that you may require  $C_{az}$  very large value and if it is a very large, obviously it cannot be monolithically integrated. You have to get it outside your chip external. Multi-stage amplifier topologies sometimes are used and here  $F_c$  is larger than  $F_s$ .  $F_s$  is a sampling frequency. A residual offset of 1 to 100 microvolt is sometimes reported.

(Refer Slide Time: 46:47)

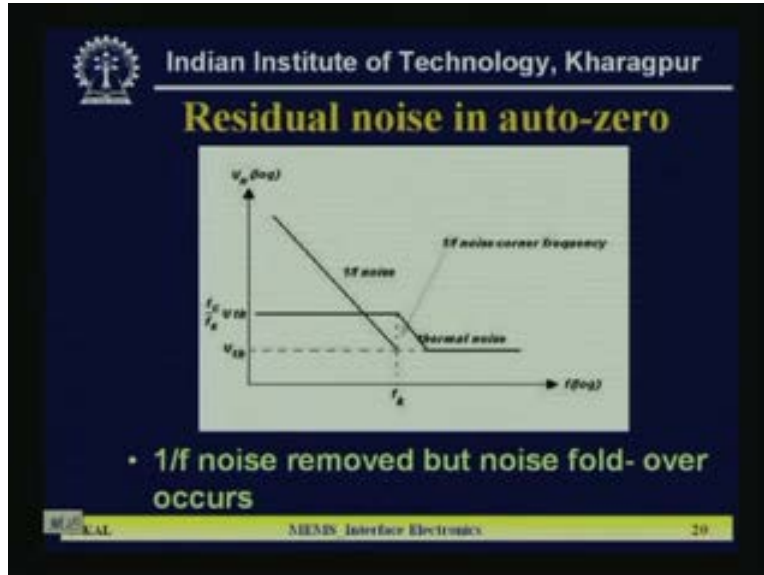

Now in auto zero technique the noise picture looks like this. Here you can see without the low frequency noise cancellation technique is auto zero, the frequency 1/f noise or like that. But after that you can see here this height this 1/f noise has been reduced to this particular point and here is the one frequency point  $f_k$  which is known as 1/f noise corner frequency and here the thermal noise is as it is like  $V_{th}$ . But the other noise at the low, other means basically the 1/f noise frequent noise and that frequent noise is  $f_c$  by  $f_s$  into  $V_{th}$  and is constant up to that 1/f corner frequency. So that means some improvement we get it in case of auto zero technique.

(Refer Slide Time: 47:47)

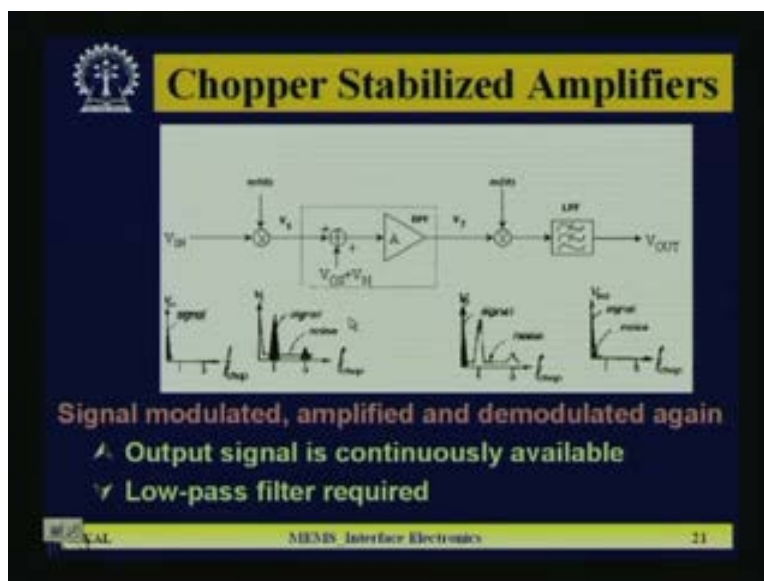

Now another technique which is used normally which is known as the chopper stabilized amplifier. So chopper stabilized amplifier is one of the preferred techniques and people use it although it is little bit complex and difficult compare to the auto zero. Here the billing blocks of the circuit are more. And here signals are first modulated then it is amplified and again demodulated and you can see here. This is the input and here you are modulating the signal and  $V_n$  input looks like here and then after modulating the  $V_1$  signal is shown here. Here you can, the signal as well as some noise are shown here and then this is the block where you can the offset and  $V_n$  both are added here and after that the modulated signal and addition of  $V_{os}$  which is offset and noise signal is fed to an amplifier and then the output is again coming to a another modulator which is basically works for demodulator. Then low pass filter and you are getting the low frequency signal output here where the other parts of the noise due to the offset and the offset error and other three corners parts are removed from the output. Now here the output signal are continuously you are getting without that frequent noise and offset. But here the problem is you have to have one addition filter which is low pass filter you have to connect at the output.

(Refer Slide Time: 49:32)

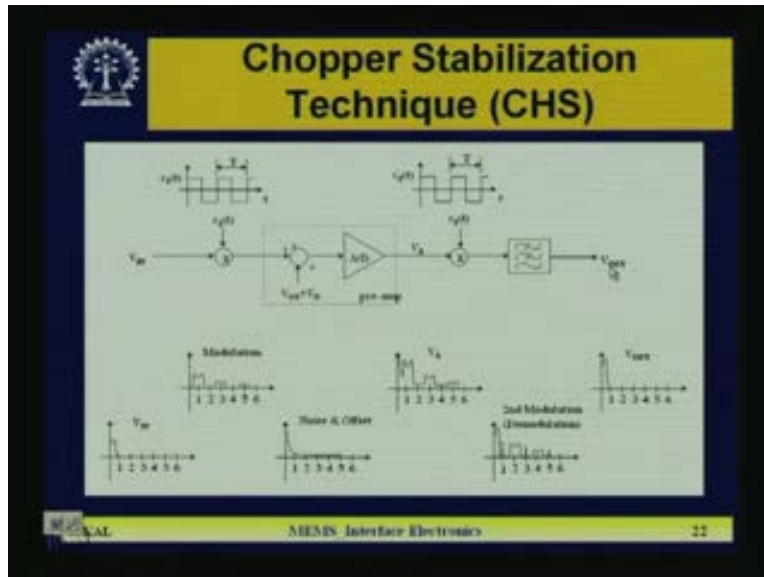

Now this is a chopper stabilization technique is shown here. Here is basically the wave in in terms of the waveform. This is the  $V_n$  same as earlier diagram little bit elaborate the waveform. Here is after modulation you will get the waveforms looks like that. Then noise and offset is separated the  $V_{os}$  and  $V_n$  these you are adding here. Then you are preamplifier, after that  $V_a$  will be here. Because this thing and this thing are added at the amplifier, output now this  $V_a$  is fed here and after the second modulation that is done here and the second modulation and you can get the signal which looks like this. There low pass filtering out then you are getting the  $V$  output here. So this is the complete flow of the chopper stabilization technique; CHS technique.

(Refer Slide Time: 50:31)

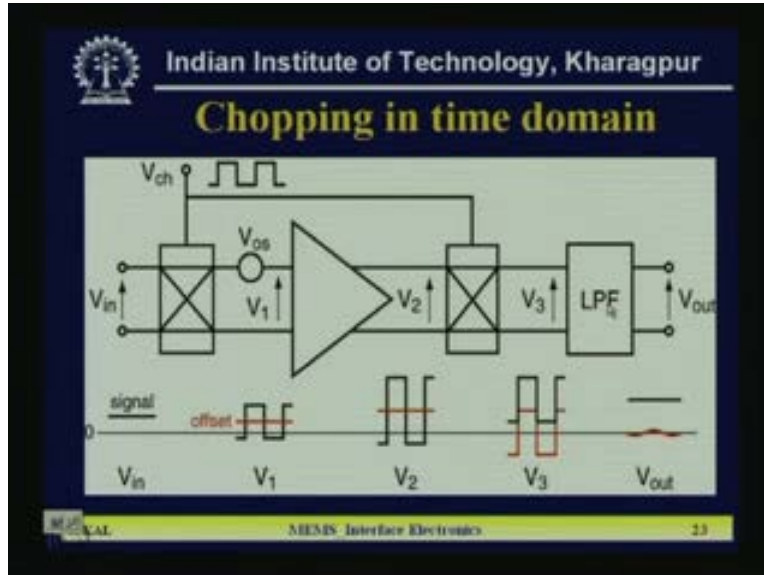

Now chopping is done in the time domain. So how it working is again explained in this diagram. So here is the V input is because I told you the signal is almost DC. So it is shown here, this is from zero level to this signal level, here. Now the V chopper that is the basically some digital signal is added the V chopper when this coming here. Then we are getting  $V_1$  where the offset is here and this is mixed with that in the modulation technique. So after that you are getting the amplifier then after amplification the output is looks like that a red line is offset and the this signal which is V chopper is connecting together along with the signal. Now what is going on the again at the V output the V chopper is again fade into that the second modulation scheme and after that, this signal and this signal added together at the  $V_3$  and if you view the low pass filter then we can see the output which is offset is comes to almost zero level and the desired signal has been amplified and which is separated out. So that is the chopping in the time domain the how a  $V_{in}$ ,  $V_1$ ,  $V_2$ ,  $V_3$  and  $V_{out}$  looks like different stages it is shown here.

(Refer Slide Time: 51:57)

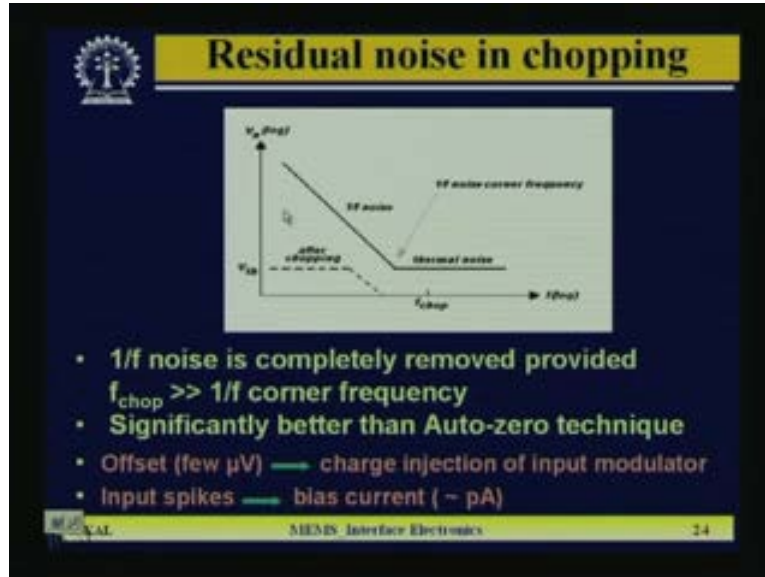

Now here in this particular case in the chopper stabilize amplifier gives you the output. You can see here that offset which is basically thermal noise gives you the steady offset. And that offset has brought down to 0. But at the low frequency noise has some thermal voltage at the low frequency and after that this technique completely removes the drift or the offset arises due to thermal noise. So here  $1/f$  noise is completely removed provided,  $f_{chop}$  is large compare to  $1/f$  corner frequency. That is one of the condition significantly better than auto zero technique. That is clear form the noise response curve in case of auto zero technique in the and also the chopper stabilization technique. So offset of few microvolt, charge injection of the input modulator. Because of that input spikes are there and this come because of the bias current is of the unit of pico ampere.

(Refer Slide Time: 53:05)

Indian Institute of Technology, Kharagpur

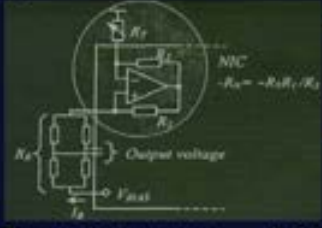

**Temperature Drift Compensation Circuit**

Temp. increases  $\rightarrow$  bridge resistance decreases  $\rightarrow$  bridge sensitivity reduces

If we made  $I_B$  to depend inversely on bridge resistance  $R_B$ , output voltage becomes temperature insensitive

MEMS Interfac Electronics 25

Now some of the circuits which I mentioned earlier in case of my lecture on accelerometer I am repeating here since I am discussing now, the interface electronics, one of the parameter, this is a temperature drift. That should be minimized and there done with the help of certain circuits which is NIC technique. So this NIC technique which is basically the negative impedance converter NIC. So this negative impedance converter there some resistance is connected which is  $R_1$  by  $R_2$  by this circuit. If some positive resistance change is there due to temperature, the total  $R_B$  then that all be compensated by another resistance which is minus  $R_n$ .

What is increasing here, that will compensated by reducing that. So in the different circuit technique which is connected at the Wheatstone's bridge output. So that the whole thing will be temperature compensated at the bridge level. So the temperature increases, bridge resistance decreases and bridge sensitivity also reduce. If we made the  $I_B$  this current bias current.  $I_B$  to depend inversely on bridge resistance  $R_B$ .  $R_B$  is the total bridge resistance the output voltage becomes temperature insensitive. That is our job. The  $I_B$  should depend inversely on total bridge resistance  $R_B$ . So that is done with the help of the impedance converter and that detail circuit diagram is shown here.

(Refer Slide Time: 54:53)

Indian Institute of Technology, Kharagpur

### Temperature Drift Compensation Circuit

A negative impedance converter (NIC) implements a negative resistance ( $-R_N$ ) in series with  $R_B$  such that  $I_B$  increase with temperature.  $R_N = (R_T / R_1 / R_2)$ ,  $R_T$  can be adjusted externally

MEMS Interfac Electronics 26

It implements a negative resistance minus  $R_N$  as shown in earlier diagram in series with the  $R_B$ .  $R_B$  is the total resistance of the bridge such that if  $I_B$  increased with temperature the  $R_N$  is equal to  $R_T$  into  $R_1$  by  $R_2$  and  $R_T$  can be adjusted externally with some potentiometer or some other part.

(Refer Slide Time: 55:22)

Indian Institute of Technology, Kharagpur

### MAX1457 At-A-Glance

0.1% Accurate Signal Conditioner for Piezoresistive Sensor Compensation

MEMS Interfac Electronics 27

So now this is some chip in that direction temperature compensation chips are also available. Readymade chips which is maxim 1457 and which gives you 0.1 percent accurate signal conditional circuit chip for piezoresistor resistive sensor compensation.



(Refer Slide Time: 55:41)

Indian Institute of Technology, Kharagpur

**MAX1457 At-A-Glance**  
**0.1% Accurate Signal Conditioner for Piezoresistive Sensor Compensation**

Part Number	PGA	Calibration Method	Accuracy (% FSO)	Output Type	Supply Voltage (V)	Typical Supply Current (mA)	Sensor Excitation Current (mA)	Package	Op. Range (°C)	Price (US \$)
MAX1457	3-bit	Internal DACs updated from external EEPROM	0.1	Analog	4.5 to 5.5	2.5	0.1 to 2.8	28-pin SOIC, 16-pin PDIP, 8-pin SSOP	-40 to +125	\$2.0

MEAS. KAL MEMS Interface Electronics 28

This chip configuration is shown here and its detail characteristics of maxim 1457 is also mentioned in this diagram which reveals that it is a very good chip for piezoresistive sensors and it can go minus 40 to plus 125 without any problem. So that temperature variation has been compensated inside the chip itself.

(Refer Slide Time: 56:11)

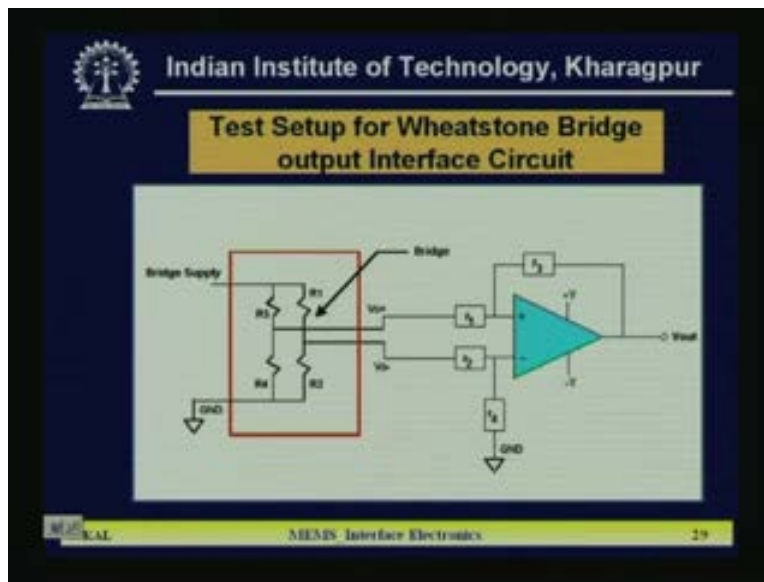

Now these are some of the simple circuits which can give you some offset cancellation also. That is the bridge output is connected with 4 resistances;  $R_1$ ,  $R_2$ ,  $R_3$ ,  $R_4$  and by adjusting these 4 resistances the offset voltage can be drastically reduced.

(Refer Slide Time: 56:32)

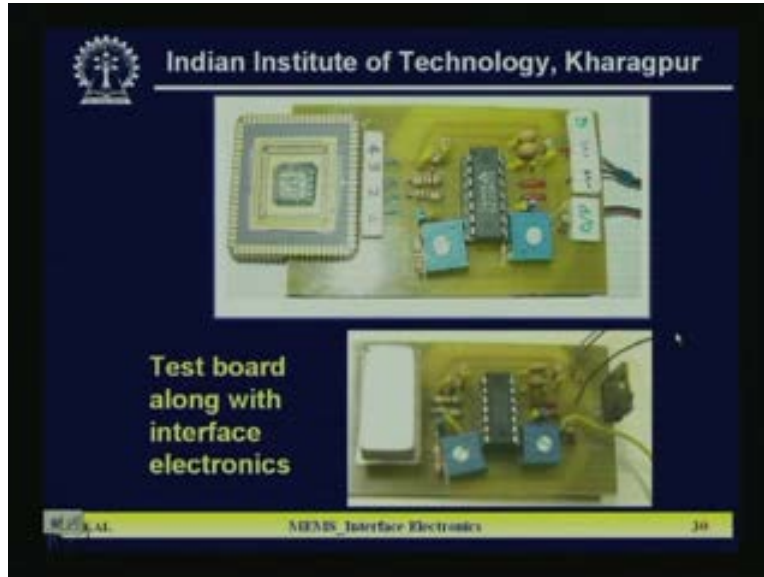

And that technique we have used in our case. In our accelerometer and here the circuits this, a TC 7652 is basically your chopper stabilized amplifier which has got advantage. Also in case of the offset cancellation  $1/f$  noise cancellation and along with that we have used 4 resistances to further reduce the offset value and that in a PCB package we have made along with accelerometer. Both this and this one are accelerometer on different packages and the circuit is the same.

(Refer Slide Time: 57:07)

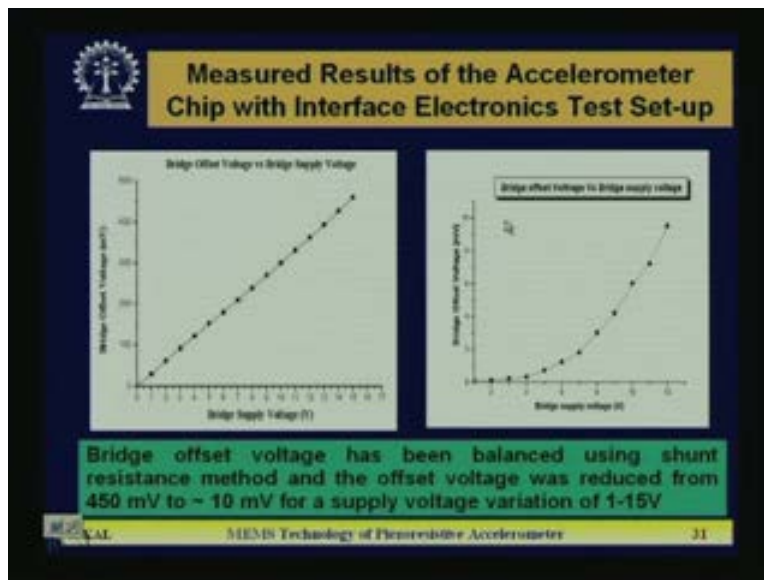

And there we can get rid of the offset value drastically you can if you look on the two curves, you can see bridge offset has been balanced using the shunt resistances which are

$R_1, R_2, R_3, R_4$  as mentioned in the earlier diagram and offset voltage was reduced from 450 millivolt to minus 10 millivolt. Only for a supply voltage variation to 1 to 15 volt. With that supply voltage variation, you can reduce initially it was 450 and it has reduced to 10 millivolt only.

(Refer Slide Time: 57:43)

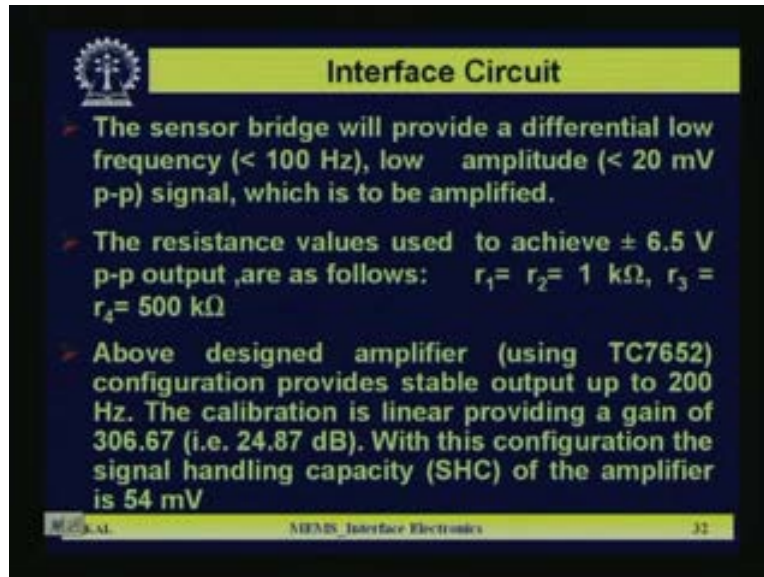

**Interface Circuit**

- The sensor bridge will provide a differential low frequency ( $< 100$  Hz), low amplitude ( $< 20$  mV p-p) signal, which is to be amplified.
- The resistance values used to achieve  $\pm 6.5$  V p-p output, are as follows:  $r_1 = r_2 = 1$  k $\Omega$ ,  $r_3 = r_4 = 500$  k $\Omega$
- Above designed amplifier (using TC7652) configuration provides stable output up to 200 Hz. The calibration is linear providing a gain of 306.67 (i.e. 24.87 dB). With this configuration the signal handling capacity (SHC) of the amplifier is 54 mV

SIIT Interface Electronics 32

So now with that let me conclude the sensor bridge which we have developed in our laboratory. We have come to a certain hybrid mode interface circuit which is also giving good result. So far as offset is concerned, but temperature compensation is not there much perfect. So this bridge which we used for our circuit provide differential low frequency less than 100 hertz, slow amplitude less than 20 millivolt signal which is to be amplified and in that case this amplification has been done after 6.5 volt in chopper stabilize amplified with  $r_1, r_2$  1 kilo ohm  $r_3, r_4$  with 500 kilo ohm and the TC7652 configuration provides stable output up to 200 hertz. So this is basically some small example which are doing here, but that is not the final. You have to design separate blocks using your required chopper stabilization techniques amplifiers and all other things if you want to have monolithic interface electronic chip for any kind of sensors. So there as work going on, nowadays for universal interface electronics. So the interface electronic chip can be connected to any kind of sensor; either it is a piezoresistive piezocapacitive or may be other kind of sensor. So these are the thing three things we have discussed today. So let me stop here. Thank you very much.